



Embedded-Based Office Automation with Real-Time Energy Tracking

Prof M.Balasubramanian¹, M.DhatchMhana², E.Kaviyarasu³, K.Sakthi⁴ M.Naveenkumar⁵

¹Assistant Professor, Department of Electrical and Electronics Engineering,
JAYALAKSHMI INSTITUTE OF TECHNOLOGY, THOPPUR.

^{2,3,4,5} UG Students, Department of Electrical and Electronics Engineering, JAYALAKSHMI INSTITUTE OF
TECHNOLOGY, THOPPUR.

bala3171981@gmail.com, dhatchanamunusamy@gmail.com, ksakthi1073@gmail.com
kaviram095@gmail.com, naveenkumar.eee016@jit.net.in

How to Cite this Article:

M.DhatchMhana, E.Kaviyarasu, K.Sakthi, & M.Naveenkumar, (2026). Embedded-Based Office Automation with Real-Time Energy Tracking. International Journal of Creative and Open Research in Engineering and Management, <i>02</i>(03).
<https://doi.org/10.55041/ijcope.v2i3.252>

License:

This article is published under the terms of the Creative Commons Attribution 4.0 International License (CC BY 4.0), which permits unrestricted use, distribution, and reproduction in any medium, provided the original author(s) and the source are credited.

© The Author(s). Published by International Journal of Creative and Open Research in Engineering and Management.



<https://doi.org/10.55041/ijcope.v2i3.252>

ABSTRACT

The rapid advancement of embedded systems and the growing need for energy efficiency have led to the development of intelligent office automation solutions. This project presents an embedded-based office automation system integrated with real-time energy tracking to enhance operational efficiency, reduce power consumption, and promote sustainable energy usage.

The proposed system utilizes microcontroller-based architecture to automate and control electrical appliances such as lighting, air conditioning, and office equipment. Sensors are employed to monitor parameters like occupancy, temperature, and device usage, enabling intelligent decision-making for optimal resource utilization. A real-time energy tracking module continuously measures power consumption and provides live feedback to users through a user interface or connected application.



INTRODUCTION

Smart office automation is an emerging technology that integrates embedded systems, sensors, and communication networks to create an intelligent and efficient workplace environment. With the increasing demand for energy conservation and operational efficiency, traditional office setups are being replaced by automated systems capable of monitoring and controlling various electrical devices.

Embedded systems play a crucial role in smart office automation by enabling real-time control and decision-making. These systems are designed to automate functions such as lighting, air conditioning, and other office equipment based on environmental conditions and user presence. By using sensors like motion detectors, temperature sensors, and light sensors, the system ensures that energy is utilized only when required.

One of the key features of modern smart offices is real-time energy tracking. This functionality allows continuous monitoring of power consumption, providing valuable insights into usage patterns. With this information, organizations can identify energy wastage, optimize resource usage, and significantly reduce electricity costs.

Furthermore, the integration of Internet of Things (IoT) technology enhances the system by enabling remote monitoring and control through mobile or web applications. This not only improves convenience but also ensures better management of office infrastructure.

Literature Review

The concept of office automation has evolved significantly with advancements in embedded systems and Internet of Things (IoT) technologies. Various researchers have contributed to the development of smart automation systems focused on improving energy efficiency, user comfort, and system reliability.

Early automation systems were primarily based on manual control and timer-based operations, which lacked flexibility and real-time adaptability. With the introduction of microcontrollers, researchers developed embedded-based automation systems capable of controlling devices such as lights and fans automatically. These systems laid the foundation for intelligent control but had limited monitoring capabilities.

Recent studies have emphasized the integration of IoT with embedded systems to enable remote monitoring and control. Researchers have proposed smart office systems that utilize wireless communication technologies such as Wi-Fi, Bluetooth, and Zigbee. These systems allow users to manage office appliances through mobile applications, improving convenience and accessibility.

System Overview

The proposed system, *Embedded-Based Office Automation with Real-Time Energy Tracking*, is designed to automate office appliances while continuously monitoring and analyzing energy consumption. The system combines embedded hardware, sensors, and communication technologies to create an intelligent and energy-efficient office environment.

At the core of the system is a microcontroller, which acts as the central processing unit. It interfaces with various sensors such as motion sensors for occupancy detection, temperature sensors for climate monitoring, and current sensors for measuring energy consumption. Based on the sensor inputs, the microcontroller makes real-time decisions to control devices like lights, fans, and air conditioning systems.



The automation process works by detecting the presence of users and environmental conditions. For example, when a person enters a room, the motion sensor activates the lighting system, and when the room is vacant, the system automatically turns off the appliances to save energy. Similarly, temperature sensors regulate cooling systems to maintain a comfortable environment while minimizing power usage.

The system controls output devices such as lights, fans, air conditioners, and security alarms through relays or driver circuits. For example, lights are automatically turned on when motion is detected and turned off when the room is unoccupied.

Similarly, temperature sensors help regulate fans or air conditioning systems to maintain a comfortable working environment.

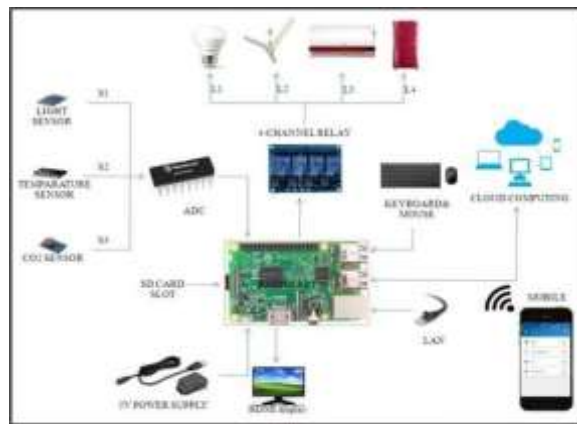
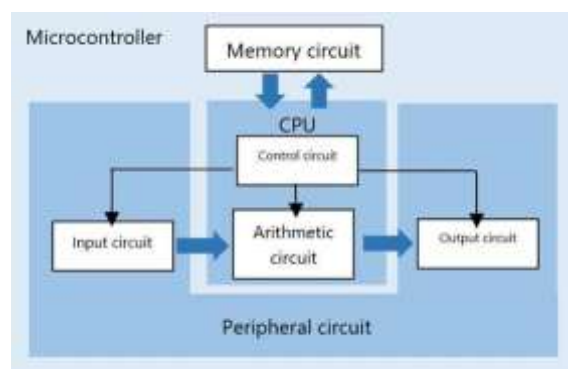

Fig. 1.1 Architecture of the office automation system.

Hardware

The hardware components form the backbone of the embedded-based office automation system. These components work together to sense environmental conditions, process data, and control electrical appliances efficiently

BLOCK DIAGRAM:



RECEIVER:



BLOCK DIAGRAM:



Software

The software component of the system is responsible for controlling hardware operations, processing sensor data, and enabling user interaction. It plays a vital role in ensuring efficient automation and accurate real-time energy tracking.

The Embedded is programmed using development platforms such as the Arduino IDE or other embedded system tools depending on the controller used. These platforms provide an easy interface to write, compile, and upload code to the Embedded.

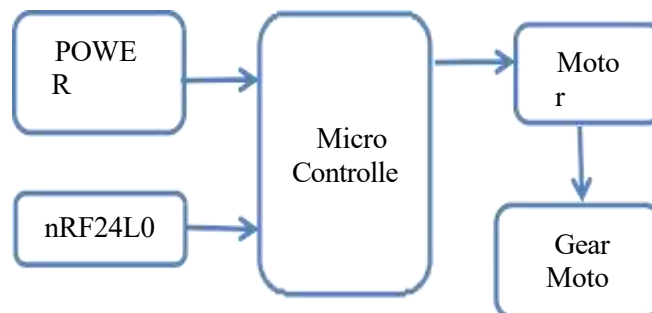

The software continuously reads data from the current sensor and calculates power consumption. It may compute parameters such as voltage, current, power, and energy usage (in kWh). This data is updated in real time and can be displayed or transmitted for further analysis.

CONCLUSION AND FUTURE WORK

The *Embedded-Based Office Automation with Real-Time Energy Tracking* system presents an efficient and intelligent solution for modern workplace management. By integrating embedded systems with sensors and communication technologies, the system successfully automates the control of office appliances based on real-time environmental conditions and user presence.

The implementation of real-time energy tracking enables continuous monitoring of power consumption, helping to identify energy wastage and optimize usage. This not only reduces electricity costs but also contributes to environmental sustainability. The system enhances user convenience through automated operations and remote accessibility, making it a practical and scalable solution for smart offices.



Overall, the project demonstrates how technology can be effectively utilized to improve energy efficiency, operational control, and comfort in office environments.

Although the system provides significant benefits, there are several areas for further improvement and enhancement: **Advanced Security Features:** Adding biometric authentication, facial recognition, and real-time alert systems can enhance security.

- **Energy Monitoring System:** Incorporating energy consumption tracking can help in analyzing and reducing power usage further.
- **Scalability Improvements:** The system can be extended to support large-scale office buildings with centralized control.

References

- [1] M. Bhuyar and A. Ansari, "Design and Implementation of Smart Office Automation System," *International Journal of Engineering Research and Applications (IJERA)*, vol. 6, no. 10, pp. 45–50, 2016.
- [2] A. Kumar, S. Tiwari, and R. Gupta, "IoT Based Smart Office Automation System," *International Journal of Modern Engineering Research (IJMER)*, vol. 7, no. 3, pp. 12–18, 2017.
- [3] D. Pavithra and R. Balakrishnan, "IoT Based Monitoring and Control System for Smart Buildings," *International Journal of Innovative Research in Science, Engineering and Technology (IJIRSET)*, vol. 4, no. 6, pp. 4957–4962, 2015.
- [4] S. Madakam, R. Ramaswamy, and S. Tripathi, "Internet of Things (IoT): A Literature Review," *Journal of Computer and Communications*, vol. 3, no. 5, pp. 164–173, 2015.
- [5] V. N. Gudivada, "Smart Buildings and Intelligent Automation Systems," *IEEE Computer Society*, pp. 1–6, 2018.
- [6] Arduino, "Arduino Official Documentation," [Online].
- [7] Espressif Systems, "ESP8266 Wi-Fi Module Datasheet," [Online].
- [8] K. Ashton, "That 'Internet of Things' Thing," *RFID Journal*, 2009.