



IoT-Enhanced Gesture Controlled Robotic Vehicle Using RF Communication

Prof C.Suresh¹, K.Bakyalakshmi², C.Divyasri³, M.Gunasekaran⁴ M.Isravel⁵

¹Assistant Professor, Department of Electrical and Electronics Engineering,
JAYALAKSHMI INSTITUTE OF TECHNOLOGY, THOPPUR.

^{2,3,4,5} UG Students, Department of Electrical and Electronics Engineering,
JAYALAKSHMI INSTITUTE OF TECHNOLOGY, THOPPUR.

hodeee@jit.net.in, bakyalakshmi.k505@gmail.com, divyasrivkd@gmail.com,
guna52316@gmail.com, Isravelisravel266@gmail.com

How to Cite this Article:

K.Bakyalakshmi, C.Divyasri, M.Gunasekaran, & M.Isravel, (2026). IoT-Enhanced Gesture Controlled Robotic Vehicle Using RF Communication. International Journal of Creative and Open Research in Engineering and Management, <i>02</i>(03).
<https://doi.org/10.55041/ijcope.v2i3.249>

License:

This article is published under the terms of the Creative Commons Attribution 4.0 International License (CC BY 4.0), which permits unrestricted use, distribution, and reproduction in any medium, provided the original author(s) and the source are credited.

© The Author(s). Published by International Journal of Creative and Open Research in Engineering and Management.



OPEN ACCESS



<https://doi.org/10.55041/ijcope.v2i3.249>

ABSTRACT

This paper presents the design and implementation of an Internet of Things (IoT)-enhanced gesture-controlled robotic vehicle using radio frequency (RF) communication. The proposed system enables intuitive human-machine interaction by translating hand gestures into directional commands for real-time vehicle navigation. A wearable gesture module equipped with an accelerometer sensor captures hand movements and processes them using a microcontroller. The interpreted signals are transmitted wirelessly via an RF transmitter to a receiver module mounted on the robotic vehicle. The vehicle unit, integrated with a microcontroller, decodes the received signals and controls the motors accordingly to achieve precise movement.



INTRODUCTION

The rapid advancement of Internet of Things (IoT) has significantly transformed the way devices interact and communicate, enabling smarter and more efficient systems across various domains. One of the most promising applications of IoT lies in the field of automation and robotics, where intelligent control mechanisms can enhance performance, flexibility, and user convenience.

This project presents the design and development of an IoT-enhanced gesture- controlled robotic vehicle using Radio Frequency Communication (RF communication). The system allows users to control the movement of a robotic vehicle through simple hand gestures, eliminating the need for traditional input devices such as joysticks or remote controllers. Gesture inputs are captured using sensors, processed by a microcontroller, and transmitted wirelessly via RF modules to the vehicle.

Gesture	command
→	turn right
←	Turn left
↑	Go straight
↓	Go Back
↻	rotate
⤴	STOP

Fig. 1. The six hand gestures used to navigate a robotic-vehicle.

The integration of IoT technology further enhances the system by enabling real-time monitoring, data transmission, and potential remote operation over the internet. This not only improves the functionality of the robotic vehicle but also opens up possibilities for applications in areas such as surveillance, search and rescue operations, assistive technologies, and industrial automation.

By combining gesture recognition, RF communication, and IoT capabilities, this project aims to develop an intuitive, efficient, and cost-effective solution for modern robotic control systems.

Literature Review

Recent advancements in robotics and human– machine interaction have led to significant research in gesture-controlled robotic systems integrated with wireless communication and IoT technologies. Gesture-based control is considered a natural and intuitive method, improving user interaction and reducing dependency on traditional control devices.

Several researchers have explored gesture- controlled robotic systems using accelerometer-based input devices. For instance, a study on gesture-controlled robotic systems using RF modules demonstrated that hand movements captured through accelerometers can be processed using microcontrollers and transmitted wirelessly to control robotic actions such as movement direction . These systems typically employ transmitter and receiver units, where gesture data is encoded and sent via RF communication to drive motors accordingly.



System Overview

The proposed system, an IoT-enhanced gesture-controlled robotic vehicle, is designed to enable intuitive and wireless control of a robotic platform using hand gestures. The system integrates gesture recognition, Radio Frequency Communication (RF communication), and Internet of Things (IoT) technologies to achieve efficient and real-time operation.

The overall system is divided into two main sections: the transmitter unit and the receiver unit.

The **transmitter unit** is responsible for capturing user gestures. It typically consists of an accelerometer sensor mounted on a wearable device such as a glove. The sensor detects hand movements and converts them into electrical signals. These signals are then processed by a microcontroller, which interprets the gestures into specific movement commands such as forward, backward, left, and right. The processed data is transmitted wirelessly using an RF transmitter module.



Fig. 2. The accelerometer module

1. Hardware

The system is designed to control a robotic vehicle using hand gestures, enhanced with IoT capabilities for monitoring and remote interaction. The gesture data is captured using sensors, processed by a microcontroller, transmitted via RF communication, and executed by the robot. IoT integration enables real-time data visualization and control over the internet.

TRANSMITTER:

BLOCK DIAGRAM:

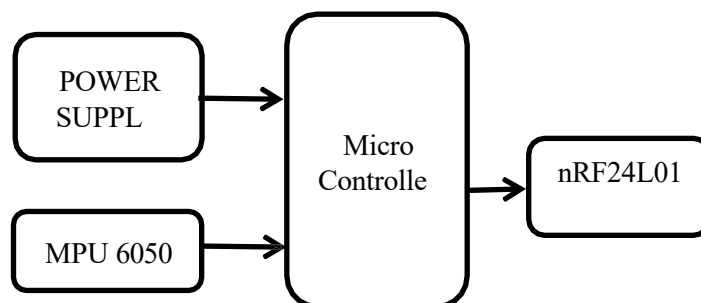

RECEVIER:



BLOCK DIAGRAM:

2. Software

The software component is responsible for acquiring gesture data, processing it into control commands, transmitting it via RF communication, and enabling IoT-based monitoring and control. It integrates embedded programming, communication protocols, and cloud platforms.

The system is typically developed using:

- Arduino IDE

Used to write, compile, and upload code to microcontrollers like Arduino, ESP8266, or ESP32.

- C++

Primary language for embedded system programming.

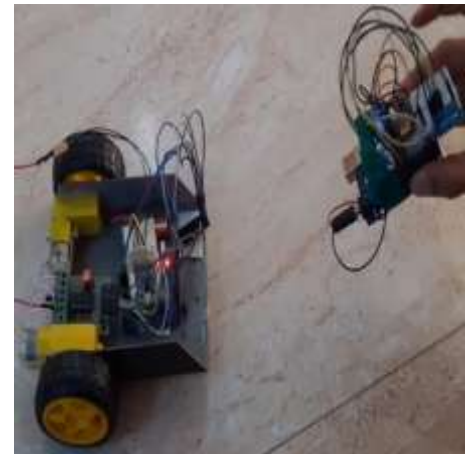
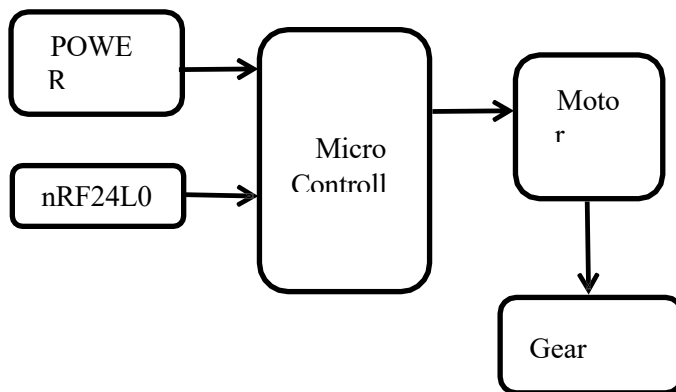

Fig. 3. module of Gesture controller

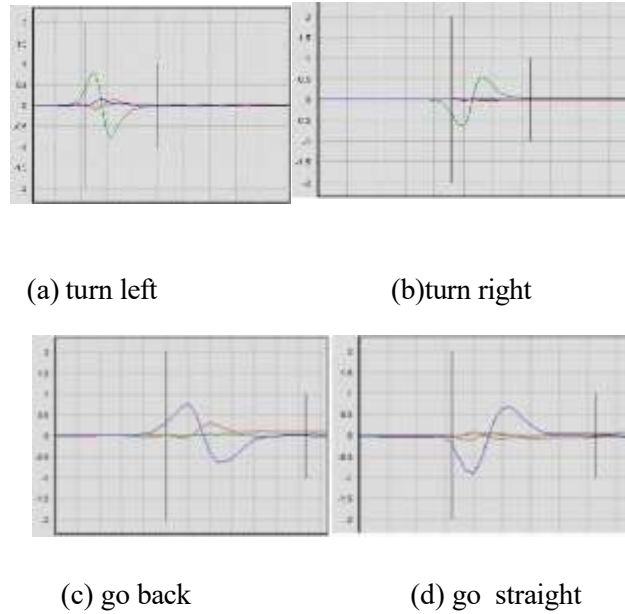

Fig.4. An example of the trajectory for each hand gesture. A long vertical line indicates a starting point and a short vertical line indicates an ending point. Blue lines mean the z-axis, red lines mean the x-axis, and green lines mean the y-axis. (a) Turn right (b) Turn left (c) Go straight (d) Go back .

CONCLUSION AND FUTURE WORK

The project **IoT-Enhanced Gesture Controlled Robotic Vehicle Using RF Communication** successfully demonstrates an intuitive and wireless method of controlling a robotic system using human gestures. By integrating an accelerometer- based gesture sensing unit with RF communication, the system enables real-time control of the robot without the need for physical interfaces.

The use of microcontrollers ensures efficient processing of gesture data and accurate execution of movement commands. The RF communication module provides a reliable and low-cost wireless link between the transmitter and receiver units. Additionally, the integration of IoT enhances the system by enabling remote monitoring and control through internet-based platforms.

Overall, the project highlights the effective combination of embedded systems, wireless communication, and IoT technologies to create a user-friendly and scalable robotic control system. It serves as a foundation for developing more advanced human-machine interaction systems.



References

1. Patel, K., Makwana, R., Bhavsar, D., Chauhan, S., & Gandhi, S.
“IoT Based Hand Gesture Control Robot,” *International Journal of Engineering Research & Technology (IJERT)*, Vol. 12, Issue 09, 2023.
– Discusses IoT integration with gesture- controlled robotic systems.
2. Arunachalam, M., & Naveenkumar, P. “Gesture Controlled Robot with Wireless Communication,” *IJERT Conference Proceedings*, 2019.
– Explains RF-based wireless gesture control in robotics.
3. Suresh Babu, C. V., et al.
“Smart Gesture Controlled Systems Using IoT,” in *AI-Based Digital Health Communication*, IGI Global, 2023.
– Covers gesture recognition and IoT-based control systems.
4. Kadam, S., Jadhav, V., Takur, R., Nakate, S., & Chavan, D.
“Gestures Controlled Robot,” *International Journal for Research in Applied Science & Engineering Technology (IJRASET)*, 2024.
– Describes accelerometer-based gesture control using microcontrollers.
5. Gomathy, C. K., et al.
“The Gesture Controlled Robot,” *International Research Journal of Engineering and Technology (IRJET)*, Vol. 8, Issue 4, 2021.
– Provides fundamentals of gesture-based robotic systems.
6. Sara, M., et al.
“Gesture Controlled Robot for the Disabled Using Arduino,” *IJRASET*, 2024.
– Demonstrates wireless gesture transmission and robotic control.
7. Nair, R. S., Kumar, S., Soumya, N., & Shanmugasundaram, M.
“A Study on Gesture Controlled Robotic Arms and Their Implementations,” *International Journal of Mechanical Engineering and Technology*, 2018.
– Reviews multiple gesture-control techniques and IoT applications.
8. Gharibi, A., et al.
“RF-Based Robotic Systems for Object Recognition,” *Electronics Journal (MDPI)*, 2025.
– Highlights RF communication and sensing in robotics.
9. Du, G., et al.
“Gesture-Based Robot Teleoperation Methods,” *Scientific Reports / IEEE References*, 2023.
– Discusses advanced gesture recognition and robotic control techniques.