



Smart Auto-off Water Heater System using ESP32

Dhanawade Vaishnavi Ramdas #1(vaishnavi.r.dhanawade@gmail.com)

Datir Samiksha Abhay#2(samikshadatir619@gmail.com)

Sarthak Pramod Deshmukh

Dighe Atharva Mahindra

Guided By :Prof Pathak J.G

Department of Electronics and Telecommunication

Amrutvahini polytechnic ,Sangamner ,Maharashtra

How to Cite this Article:

Ramdas, D. V., Abhay, D. S., Deshmukh, S. P. & Mahindra, D. A. (2026). Smart Auto-off Water Heater System using ESP32. International Journal of Creative and Open Research in Engineering and Management, <i>02</i>(03).
<https://doi.org/10.55041/ijcope.v2i3.086>

License:

This article is published under the terms of the Creative Commons Attribution 4.0 International License (CC BY 4.0), which permits unrestricted use, distribution, and reproduction in any medium, provided the original author(s) and the source are credited.

© The Author(s). Published by International Journal of Creative and Open Research in Engineering and Management.



<https://doi.org/10.55041/ijcope.v2i3.086>

ABSTRACT

Water heaters are widely used in homes, hostels, hospitals, and industries, but they often lead to energy wastage and safety issues when left ON unnecessarily.

This paper presents a Smart Auto-Off Water Heater System using ESP32 that automatically controls water heating and usage.

The system monitors water temperature, usage count, and object detection to prevent unnecessary water flow and power consumption.

A mobile application (Blynk) and OLED display provide real-time monitoring and control.

The proposed system improves energy efficiency, safety, and smart water management.

1. INTRODUCTION

Water heaters are essential appliances for daily use in households and institutions.

Traditional heaters often remain ON for long durations, leading to electricity wastage and overheating risks.

Manual control also increases the chances of human error and unsafe operation.

Smart automation can solve these issues by integrating sensors, microcontrollers, and IoT technology.

The proposed system uses ESP32 with sensors and mobile connectivity to automatically control the heater and water flow.

This system ensures efficient energy usage and improved user safety.

2. LITERATURE REVIEW

In previous research, many systems were developed for smart energy management in home appliances.

Some studies proposed IoT-based smart water heaters that allow remote monitoring through mobile applications.

Other research used temperature sensors and microcontrollers to control heating automatically when the desired temperature is reached.

Several automation systems also integrate object detection sensors to control water flow and prevent wastage.

These studies show that smart monitoring and automation can significantly reduce energy consumption and improve safety.

3. PROPOSED SYSTEM

The proposed system consists of the following components:

ESP32 Microcontroller – controls the entire system and processes sensor data.

Temperature Sensor – monitors the water temperature continuously.

IR/Object Sensor – detects the presence of a user and stops water flow if no object is detected.

Solenoid Valve – controls the flow of hot water automatically.

OLED Display – displays temperature, system status, and usage information.

Touch Buttons – allow users to set the required temperature.

Blynk Mobile App – provides remote monitoring and control of the heater.

System Operation:

Water heating starts when the system is activated.

The temperature sensor monitors the water temperature.

Once the preset temperature is reached, the heater automatically turns OFF

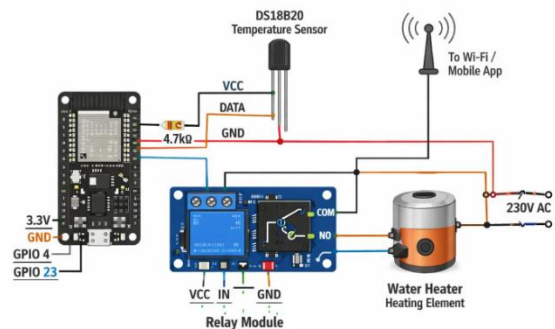

The IR sensor detects the presence of a user and allows water flow only when required.

If no object is detected, the system stops the water flow automatically. The usage counter also limits excessive use.



4. ADVANTAGES

- Reduces electricity consumption.
- Prevents overheating and safety hazards.
- Enables automatic water flow control.
- Allows real-time monitoring through mobile app.
- Improves user convenience and smart control.

5. APPLICATIONS

- Smart homes
- Hostels and hotels
- Hospitals
- Industrial water heating systems
- Energy efficient buildings

6. CONCLUSION

The Smart Auto-Off Water Heater System provides an efficient solution for reducing water and energy wastage.

The integration of ESP32, sensors, and IoT technology allows automatic monitoring and control of the heating process.

The system enhances safety, convenience, and energy efficiency compared to conventional heaters.

In the future, this system can be improved with advanced sensors and AI-based energy optimization.

7. References

- [1] N. Kolban, Kolban's Book on ESP32, 2017.
- [2] Espressif Systems, ESP32 Technical Reference Manual, 2023.
- [3] IEEE, Internet of Things Architecture and Applications, 2013.