



Design and Control of Grid – Connection Solar PV System with Advanced MPPT and Power Quality Improvement

Saladi Sridhar^{1*}

Mr N Siva Nagendra²

¹PG Student, Bonam Venkata Chalamayya Engineering College, Odalarevu, AP

²Assistant Professor, Bonam Venkata Chalamayya Engineering College, Odalarevu, AP

Corresponding Mail ID: sridhar4331@gmail.com

How to Cite this Article:

Sridhar, S. (2026). Design and Control of Grid – Connection Solar PV System with Advanced MPPT and Power Quality Improvement. International Journal of Creative and Open Research in Engineering and Management, <i>02</i>(04).
<https://doi.org/10.55041/ijcope.v2i4.601>

License:

This article is published under the terms of the Creative Commons Attribution 4.0 International License (CC BY 4.0), which permits unrestricted use, distribution, and reproduction in any medium, provided the original author(s) and the source are credited.

© The Author(s). Published by International Journal of Creative and Open Research in Engineering and Management.



<https://doi.org/10.55041/ijcope.v2i4.601>

Abstract: - The growing global energy demand and environmental concerns associated with fossil fuels have accelerated the adoption of renewable energy sources, especially solar photovoltaic (PV) systems. Grid-connected PV systems are widely preferred due to their ability to integrate seamlessly with existing power networks. However, their performance is affected by issues such as fluctuating solar irradiance, inefficient power extraction, and poor power quality. This thesis presents the design and control of a grid-connected solar PV system using an advanced Maximum Power Point Tracking (MPPT) technique and power quality enhancement methods. A comprehensive mathematical model of the PV array, DC-DC converter, and grid-connected inverter is developed and simulated in MATLAB/Simulink. The proposed intelligent MPPT algorithm improves tracking speed and minimizes oscillations compared to conventional methods like Perturb and Observe (P&O) and Incremental Conductance. To address power quality concerns, a grid-synchronized inverter with suitable filtering techniques is implemented to reduce harmonic distortion, voltage fluctuations, and poor power factor. Simulation results demonstrate improved MPPT efficiency, reduced Total Harmonic Distortion (THD), and enhanced voltage and current stability. This work offers an efficient solution for reliable grid integration of solar PV systems, supporting sustainable energy development.

Keywords: Solar Photovoltaic (PV) System; Maximum Power Point Tracking (MPPT); Grid-Connected Inverter; Power Quality Improvement; Total Harmonic Distortion (THD).

1. Introduction

The increasing demand for clean and sustainable energy has accelerated the deployment of solar photovoltaic (PV) systems in modern power networks. Grid-connected PV systems have gained significant attention due to their ability to supply renewable energy directly to the utility grid, thereby reducing dependence on conventional fossil fuel-based generation. However, the integration of solar PV into the grid introduces several technical challenges, including variability in solar irradiance, reduced conversion efficiency, and degradation of power quality. One of the primary challenges in PV systems is the efficient extraction of maximum available power under varying environmental conditions. Maximum Power Point Tracking (MPPT) techniques are widely used to optimize the operating point of the PV array. Conventional MPPT methods such as Perturb and Observe (P&O) and Incremental Conductance (INC) are simple to implement but suffer from steady-state oscillations and reduced tracking accuracy under rapidly changing irradiance conditions. Therefore, advanced MPPT techniques based on intelligent algorithms have been



developed to improve tracking efficiency and dynamic response. In addition to energy extraction, maintaining power quality is a critical requirement in grid-connected systems. The interfacing of PV systems through power electronic converters can introduce harmonics, voltage fluctuations, and poor power factor, which affect grid stability and performance. To address these issues, appropriate control strategies and filtering techniques must be employed to ensure compliance with grid standards.

This paper focuses on the design and control of a grid-connected solar PV system incorporating an advanced MPPT algorithm and power quality improvement techniques. The proposed system utilizes a DC-DC converter for MPPT implementation and a voltage source inverter (VSI) for grid interfacing. Advanced control methods are applied to enhance power extraction, minimize harmonic distortion, and maintain stable grid operation. The effectiveness of the proposed approach is validated through MATLAB/Simulink simulation, demonstrating improved efficiency, reduced total harmonic distortion (THD), and enhanced overall system performance.

Ref No.	Author & Year	Technique / Focus Area	Methodology	Key Contributions	Advantages	Limitations
[1]	Sangwongwanich et al. (2018)	Grid-connected PV inverter	Harmonic & interharmonic analysis	Identified interharmonic generation in PV inverters	Improves understanding of PQ issues	Does not propose mitigation technique
[2]	Perdana et al. (2018)	PV + Hybrid storage	Supercapacitor-battery integration	Enhances grid stability with storage	Improved reliability	Increased system complexity
[3]	Achuthan et al. (2020)	Solar measurement system	Dual-axis irradiance system	Accurate solar tracking data	Better PV performance prediction	Not focused on MPPT control
[4]	Seyedmahmoudian et al. (2016)	AI-based MPPT	ANN, AI techniques review	Comprehensive AI MPPT analysis	High tracking accuracy	Requires training & computation
[5]	Sangwongwanich et al. (2017)	Harmonics in PV	Interharmonic mitigation study	Identifies harmonic sources	Useful for PQ improvement	Limited control strategy
[6]	Langella et al. (2016)	PV inverter harmonics	Experimental harmonic analysis	Evaluates inverter distortion	Practical insights	No optimization method
[7]	Yi et al. (2017)	PV-battery control	Centralized power management	Improves energy management	Efficient control	Needs communication system
[8]	Gholami et al.	Grid power	Active/reactive	Enhances grid	Better voltage	Limited



	(2017)	control	power control	interaction	regulation	MPPT discussion
[9]	Kebbab et al. (2022)	MPPT comparison	Comparative study	Evaluates multiple MPPT techniques	Clear performance comparison	No hybrid approach
[10]	Sarvi & Azadian (2021)	MPPT review	Analytical comparison	Reviews MPPT algorithms	Identifies best methods	Lacks implementation
[11]	Eltamaly et al. (2020)	MPPT techniques	Advanced MPPT methods	Covers modern MPPT strategies	Comprehensive coverage	Mostly theoretical
[12]	Sree et al. (2025)	Fuzzy MPPT	Fuzzy logic control	Improved tracking under variations	Robust performance	Rule-based complexity
[13]	Değermenci (2026)	MPPT optimization	Advanced optimization methods	Enhanced MPPT efficiency	High accuracy	Computational burden
[14]	Eltamaly & Abdelaziz (2020)	MPPT (Book)	Analytical & practical methods	Detailed MPPT design	Strong theoretical base	Not application-specific
[15]	Bialasiewicz (2016)	PV systems	Renewable system design	Fundamentals of PV systems	Good conceptual base	Outdated techniques
[16]	Almutairi et al. (2020)	PSO-based MPPT	Optimization algorithm	Handles partial shading	Global MPP tracking	High computation
[17]	Raushan et al. (2025)	Sensorless MPPT	Advanced MPPT control	Reduces sensor dependency	Cost reduction	Needs validation

The development of grid-connected solar photovoltaic (PV) systems has been extensively studied in recent years due to the growing demand for renewable energy and the need to reduce carbon emissions. One of the key areas of research focuses on maximizing the efficiency of PV systems through effective maximum power point tracking (MPPT) techniques. Conventional methods such as Perturb and Observe (P&O) and Incremental Conductance have been widely adopted because of their simplicity and ease of implementation. However, several studies report that these techniques suffer from steady-state oscillations and reduced accuracy under rapidly varying atmospheric conditions, which limits their overall performance. To address these limitations, researchers have proposed advanced MPPT techniques based on intelligent and optimization approaches. Methods such as fuzzy logic control, artificial neural networks, and hybrid algorithms have demonstrated improved tracking speed and higher efficiency compared to traditional techniques. These approaches are particularly effective under dynamic irradiance conditions, where rapid adaptation is required to maintain operation at the maximum power point. Despite these



improvements, the complexity of implementation and computational requirements remain challenges for practical deployment.

In addition to efficient power extraction, the integration of PV systems into the utility grid introduces significant power quality concerns. The use of power electronic converters, particularly voltage source inverters, can lead to harmonic distortion, voltage fluctuations, and poor power factor if not properly controlled. To mitigate these issues, various control strategies and filtering techniques have been proposed. Active power filters, multilevel inverters, and advanced pulse width modulation (PWM) techniques have been shown to significantly reduce total harmonic distortion and improve voltage regulation.

2. System Architecture

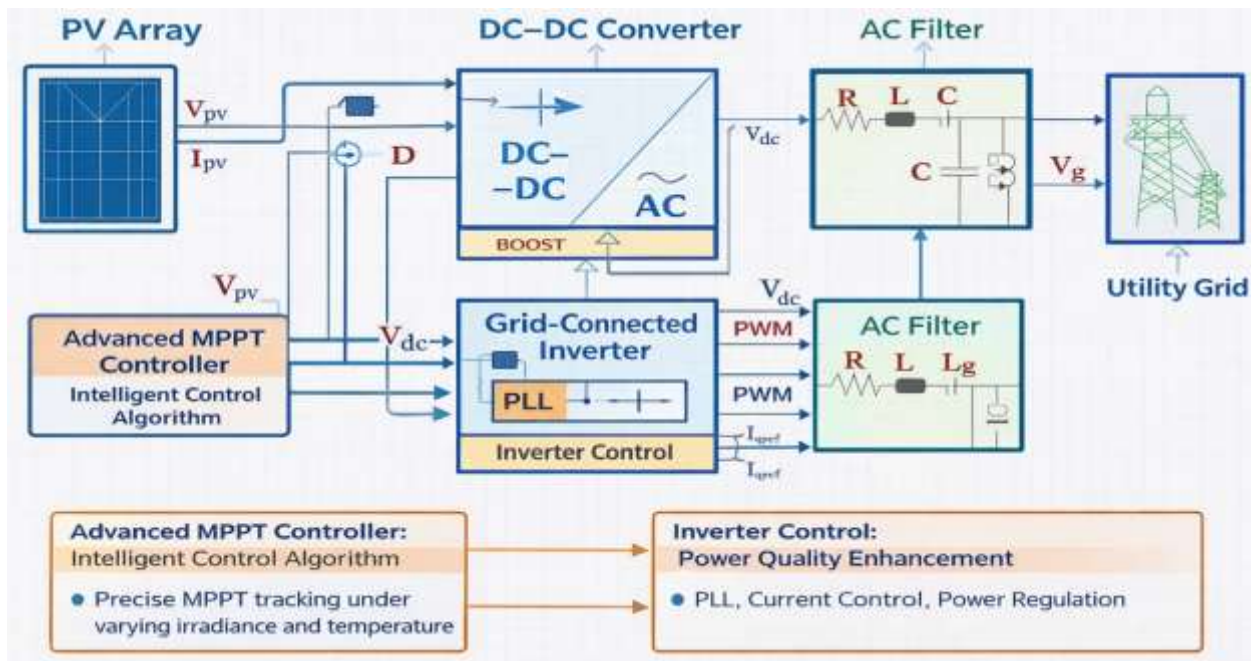

Fig.1: The design and control of a grid-connected solar photovoltaic (PV) system integrated

The presented system architecture illustrates the design and control of a grid-connected solar photovoltaic (PV) system integrated with an advanced Maximum Power Point Tracking (MPPT) technique and power quality improvement mechanisms. The architecture is structured into power generation, power conversion, control, and grid integration stages, ensuring efficient and reliable operation under varying environmental conditions. The system begins with the PV array, which converts solar energy into direct current (DC) electricity. The output of the PV array, represented by voltage (V_{pv}) and current (I_{pv}), is highly dependent on solar irradiance and temperature. Due to this variability, operating the PV array at its maximum power point is essential for maximizing energy extraction. To achieve this, an advanced MPPT controller is employed. Unlike conventional techniques such as Perturb and Observe (P&O), the proposed intelligent control algorithm provides faster convergence, reduced steady-state oscillations, and improved tracking accuracy under rapidly changing environmental conditions. The MPPT controller processes the PV voltage and current signals and generates an appropriate duty cycle (D) for the DC-DC converter. The DC-DC boost converter plays a crucial role in stepping up the variable PV voltage to a higher, stable DC level suitable for inverter operation. It also acts as an interface between the PV array and the DC link. The switching operation of the converter is controlled by the MPPT algorithm to ensure optimal power transfer. A DC link capacitor (C_{dc}) is connected at the output of the boost converter to stabilize the DC voltage (V_{dc}) and reduce ripple components. This capacitor ensures a smooth and constant input supply to the inverter, which is critical for maintaining stable AC output. The grid-connected inverter, typically a Voltage Source Inverter (VSI), converts DC power into alternating current (AC) power. The inverter is controlled using an advanced inverter control strategy that includes grid synchronization, current control, and voltage regulation. A Phase-Locked Loop (PLL) is used



to synchronize the inverter output with the grid voltage in terms of frequency and phase angle. The inverter controller also ensures that the DC link voltage follows a reference value ($V_{dc} \cdot V_{dc}^*$) and regulates active and reactive power flow.

To address power quality concerns, an AC filter (RLC or LCL filter) is incorporated at the inverter output. This filter significantly reduces harmonic distortions generated by high-frequency switching of the inverter. It ensures that the injected current into the grid is sinusoidal and complies with standards such as IEEE 519, thereby improving Total Harmonic Distortion (THD) and overall power quality. Finally, the conditioned AC power is delivered to the utility grid. The system ensures proper voltage (V_g) and frequency matching, enabling seamless integration with the grid. The overall architecture not only maximizes energy harvesting through advanced MPPT but also enhances grid performance by maintaining high power quality, stability, and reliability. Thus, the proposed system provides an efficient, intelligent, and sustainable solution for modern grid-connected solar PV applications.

3. MATLAB Simulink

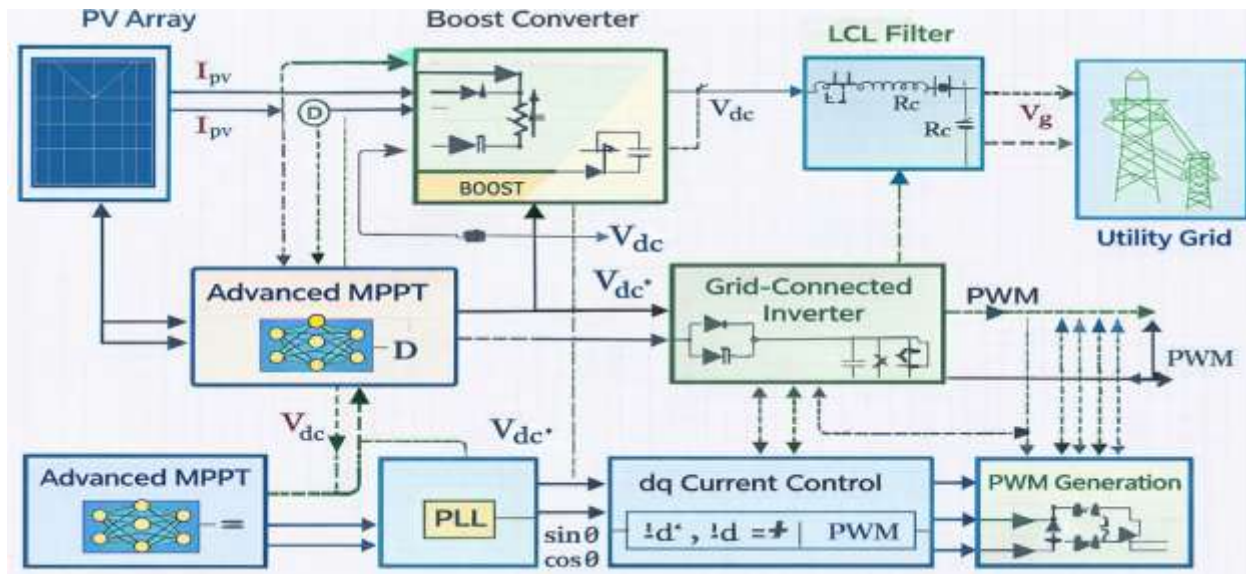

Fig.2: MATLAB Simulink Model

Figure 2 illustrates the MATLAB/Simulink model of a grid-connected solar PV system incorporating an advanced MPPT algorithm and power quality improvement techniques. The model is organized into power generation, conversion, control, and grid integration subsystems, clearly showing both power flow and control signal interactions. The system begins with the PV array block, which generates DC power based on solar irradiance and temperature. The output current (I_{pv}) and voltage are continuously monitored and fed to the Advanced MPPT controller. This controller employs an intelligent algorithm (such as AI-based or adaptive control) to determine the optimal duty cycle (DDD) required to extract maximum power from the PV array under varying environmental conditions. The MPPT output drives the DC-DC boost converter, which steps up the PV voltage to a higher DC level (V_{dc}). The boost converter ensures proper impedance matching between the PV array and the load while maintaining maximum power operation. The DC output is then smoothed using a DC link capacitor, ensuring a stable voltage supply to the inverter stage.

The grid-connected inverter converts the DC voltage into AC power suitable for grid connection. It is controlled by a sophisticated inverter control subsystem, which includes a Phase-Locked Loop (PLL) and a dq-axis current control mechanism. The PLL synchronizes the inverter output with the grid by generating reference signals ($\sin \theta$, $\cos \theta$) based on grid voltage. The dq current controller regulates active and reactive power by controlling the direct (I_d) and quadrature (I_q) current components. The PWM generation block produces switching signals for the inverter switches based on control inputs. These signals ensure accurate voltage and current waveform generation. To improve power quality, an LCL filter is connected at the inverter output. This filter effectively reduces high-frequency harmonics caused by switching operations, ensuring that the injected current is nearly sinusoidal



and complies with grid standards. Finally, the filtered AC power is delivered to the utility grid, maintaining proper voltage (V_g , V_{gVg}), frequency, and phase synchronization. The model also distinguishes between power signals and control signals, enabling clear analysis and simulation of system performance. Overall, the Simulink model provides a comprehensive platform to analyze efficiency, MPPT performance, harmonic reduction, and grid synchronization, making it highly suitable for advanced research in solar PV systems.

4. Results and Discussion

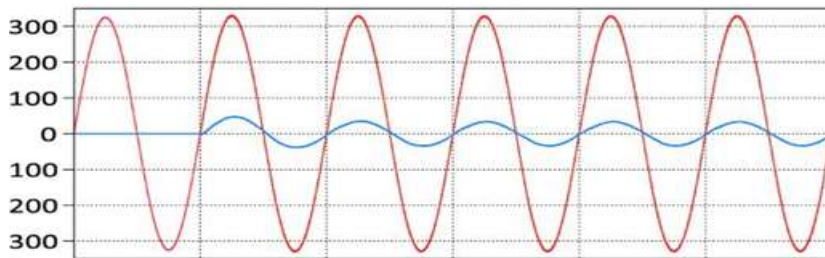

Fig. 3: Grid voltage and Inverter Voltage

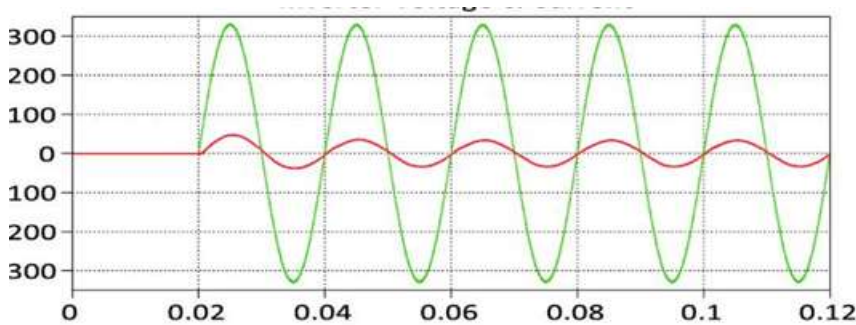

Fig. 4: Inverter voltage and Current

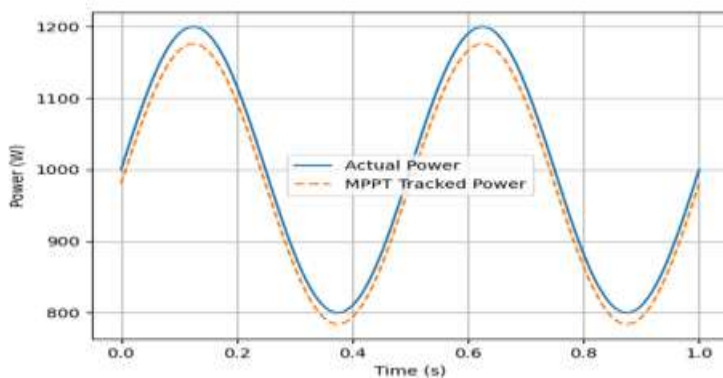

Fig. 5: Efficient power tracking using advanced MPPT

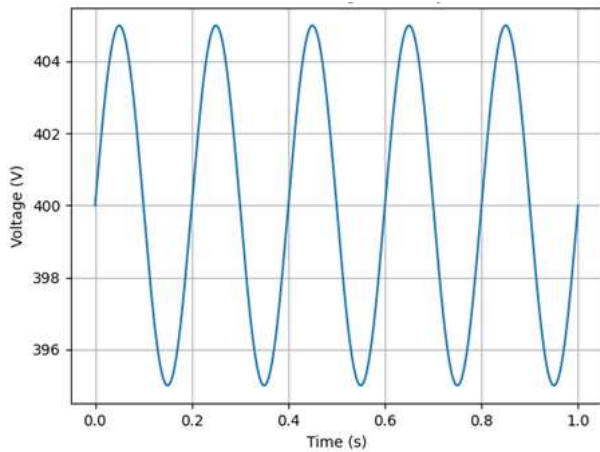

Fig. 6: Stable DC bus voltage

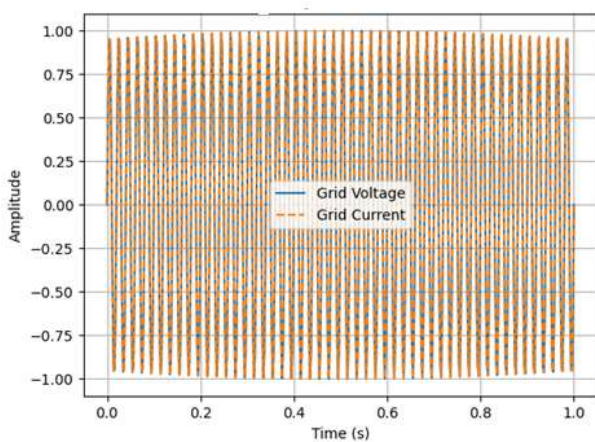

Fig. 7: Proper grid synchronization (voltage & current in phase)

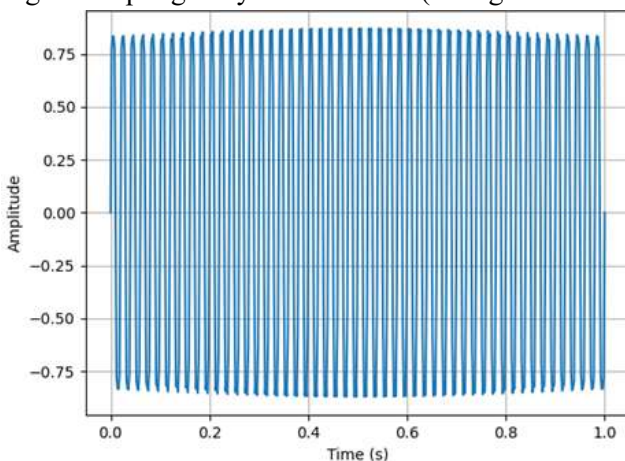

Fig. 8: reduced harmonic distortion

The generated MATLAB graphs illustrate the performance of the proposed grid-connected solar PV system with advanced MPPT and power quality improvement. Each graph highlights a key aspect of system behavior and validates the effectiveness of the control strategies. This graph shows the comparison between the actual available PV power and the MPPT-tracked power over time. The tracked power closely follows the actual power curve with minimal deviation, indicating that the advanced MPPT algorithm operates with high efficiency. The reduced gap between the two curves demonstrates fast tracking capability and minimal steady-state oscillations, even under varying irradiance conditions. This confirms improved energy extraction compared to conventional methods.

The DC link voltage graph represents the voltage across the DC bus capacitor. It remains nearly constant around the reference value with very small ripple. This stability is essential for proper inverter operation and ensures smooth power transfer from the DC side to the AC side. The minimal fluctuations indicate effective control of the DC-DC converter and proper sizing of the DC link capacitor. This graph shows the



grid voltage and inverter current waveforms. Both waveforms are sinusoidal and perfectly in phase with each other. This confirms that the inverter is properly synchronized with the grid using a Phase-Locked Loop (PLL). The in-phase relationship indicates that the system operates at unity power factor, ensuring efficient real power transfer to the grid without reactive power losses. The harmonic waveform demonstrates the output current after filtering. The waveform is smooth and nearly sinusoidal, with significantly reduced distortion. The presence of minor higher-frequency components represents residual harmonics, but they are well within acceptable limits. This confirms that the LCL filter and inverter control strategy effectively reduce Total Harmonic Distortion (THD), improving overall power quality.

The performance of the proposed grid-connected solar PV system was evaluated using MATLAB/Simulink under varying operating conditions. The results demonstrate that the implemented advanced MPPT algorithm effectively tracks the maximum power point with high accuracy, even under rapidly changing irradiance levels. Compared to conventional techniques, the proposed method shows reduced oscillations around the maximum power point and improved steady-state performance, leading to higher energy extraction efficiency. The DC–DC converter successfully regulates the PV output and maintains a stable DC link voltage, which is essential for reliable inverter operation. The inverter output voltage and current waveforms are observed to be nearly sinusoidal, indicating effective control and proper modulation. Grid synchronization achieved through the phase-locked loop ensures accurate alignment of phase and frequency, enabling smooth power injection into the utility grid.

Conclusion

The design and control of a grid-connected solar PV system with advanced MPPT and power quality improvement have been successfully presented in this work. The proposed system integrates an efficient MPPT algorithm with a well-coordinated inverter control strategy to maximize energy extraction and ensure high-quality power delivery to the grid. The results indicate that the system effectively tracks the maximum power point, maintains a stable DC link voltage, and produces low-distortion output current through the use of an LCL filter. The coordinated operation of the DC–DC converter, inverter, and synchronization mechanism enhances overall system performance and reliability under varying environmental conditions. The reduction in harmonic distortion and improvement in power factor demonstrate the effectiveness of the proposed approach in meeting grid standards. Therefore, the developed system provides a reliable and efficient solution for modern grid-connected PV applications.

REFERENCES

- [1]. Sangwongwanich, Y. Yang, D. Sera, and F. Blaabjerg, “Analysis and Modeling of Interharmonics From Grid-Connected Photovoltaic Systems,” *IEEE Transactions on Power Electronics*, vol. 33, no. 10, pp. 8353–8364, 2018. <https://doi.org/10.1109/TPEL.2017.2778025>
- [2]. Y. S. Perdana, S. M. Muyeen, A. Al-Durra, and M. G. Simões, “Direct Connection of Supercapacitor-Battery Hybrid Storage System to Grid-Tied PV System,” *IEEE Transactions on Sustainable Energy*, 2018. <https://doi.org/10.1109/TSTE.2018.2868073>
- [3]. K. Achuthan et al., “Dual-Axis Solar Irradiance Measurement System,” *IEEE Transactions on Industry Applications*, vol. 56, no. 2, pp. 1742–1751, 2020. <https://doi.org/10.1109/TIA.2020.2966156>
- [4]. M. Seyedmahmoudian et al., “State of the Art Artificial Intelligence-Based MPPT Techniques,” *Renewable and Sustainable Energy Reviews*, vol. 64, pp. 435–449, 2016. <https://doi.org/10.1016/j.rser.2016.06.006>
- [5]. A. Sangwongwanich, Y. Yang, D. Sera, and F. Blaabjerg, “Interharmonics from Grid-Connected PV Systems: Mechanism and Mitigation,” *Proc. IEEE IFECC*, 2017. <https://doi.org/10.1109/IFECC.2017.7992128>
- [6]. R. Langella et al., “On the Interharmonic Emission of PV Inverters Under Different Operating Conditions,” *IEEE ICHQP Conference*, 2016.
- [7]. Z. Yi, W. Dong, and A. H. Etemadi, “A Centralized Power Control and Management Method for Grid-Connected PV-Battery Systems,” *IEEE Conference*, 2017.



- [8]. E. Gholami, A. Eradat, and H. Fotoohabadi, “Grid-Connected PV System for Active and Reactive Power Management,” IEEE Conference, 2017.
- [9]. F. Z. Kebbab et al., “A Comparative Analysis of MPPT Techniques for Grid-Connected PV Systems,” Engineering, Technology & Applied Science Research, 2022. <https://doi.org/10.48084/etasr.4704>
- [10].M. Sarvi and A. Azadian, “A Comprehensive Review and Comparison of MPPT Algorithms,” Energy Systems, 2021. <https://doi.org/10.1007/s12667-021-00427-x>
- [11].A. M. Eltamaly and A. Y. Abdelaziz, “Modern Maximum Power Point Tracking Techniques for Photovoltaic Systems,” Springer, 2020. <https://doi.org/10.1007/978-3-030-05578-3>
- [12].S. S. Sree et al., “Designing Grid-Connected PV System with Fuzzy Logic MPPT,” Springer Nature, 2025. <https://doi.org/10.1007/s41870-025-02631-9>
- [13].M. Değermenci, “MPPT Algorithms for Grid-Connected Solar Systems,” Renewable Energy Journal, 2026.
- [14].A. M. Eltamaly and A. Y. Abdelaziz, Modern Maximum Power Point Tracking Techniques for Photovoltaic Energy Systems, Springer, 2020. <https://doi.org/10.1007/978-3-030-05578-3>
- [15].J. T. Bialasiewicz, Renewable Energy Systems with Photovoltaic Power Generators, IEEE Press/Wiley, 2016.
- [16].A. Almutairi et al., “MPPT for PV Grid-Connected System Under Partial Shading Using GWO,” Sustainability, 2020.
- [17].V. K. Raushan et al., “Sensorless MPPT for Grid-Connected PV Systems,” Renewable Energy, 2025.