



# Night Surveillance Robot With Weapon Detection

Prof M . K. Parve<sup>1</sup> Sakshi chaudhari<sup>2</sup> Suwarna kulkule<sup>3</sup> Sahil dhakate<sup>4</sup> Tanmay shende<sup>5</sup>  
Tejas chaphale<sup>6</sup>

Electrical engineering , Assistant professor<sup>1</sup>, Priyadarshini college of engineering , Nagpur  
Electrical engineering , UG student<sup>2,3,4,5,6</sup> , Priyadarshini college of engineering , Nagpur

[manjuparve2022@gmail.com](mailto:manjuparve2022@gmail.com)

[Chaudharisakshi827@gmail.com](mailto:Chaudharisakshi827@gmail.com) , [tanmayshende25@gmail.com](mailto:tanmayshende25@gmail.com) , [tejaschaphale111@gmail.com](mailto:tejaschaphale111@gmail.com) ,  
[sahildhakate70@gmail.com](mailto:sahildhakate70@gmail.com) , [suwarnamkulkule@gmail.com](mailto:suwarnamkulkule@gmail.com)

## How to Cite this Article:

chaudhari, S., kulkule, S., dhakate, S., shende, T. & chaphale, T. (2026). Night Surveillance Robot With Weapon Detection. International Journal of Creative and Open Research in Engineering and Management, <i>02</i>(04).  
<https://doi.org/10.55041/ijcope.v2i4.302>

## License:

This article is published under the terms of the Creative Commons Attribution 4.0 International License (CC BY 4.0), which permits unrestricted use, distribution, and reproduction in any medium, provided the original author(s) and the source are credited.

© The Author(s). Published by International Journal of Creative and Open Research in Engineering and Management.



<https://doi.org/10.55041/ijcope.v2i4.302>

## ABSTRACT

In recent years, the demand for advanced security systems has increased significantly due to rising safety concerns in public and private environments. This paper presents the design and implementation of a Night Surveillance Robot integrated with a Weapon Detection system. The proposed system is capable of operating in low-light or no-light conditions using infrared (IR) or night vision cameras, ensuring continuous monitoring during nighttime. The robot is remotely controlled via a mobile device through an IP-based communication system, enabling real-time video streaming and navigation.

The core feature of this system is the integration of weapon detection using image processing and machine learning techniques. The robot captures live video footage and analyzes it to identify potential threats such as firearms or sharp objects. Upon detecting a weapon, the system generates an alert notification to the user or control center, allowing immediate action. Additionally, the robot is equipped with obstacle avoidance sensors to ensure safe and efficient movement in complex environments.

This project aims to enhance security and reduce human risk by providing an automated surveillance solution suitable for applications such as military zones, border security, industrial areas,

and public spaces. The results demonstrate that the system is effective, reliable, and capable of real-time threat detection, making it a promising solution for modern surveillance challenges.

Keyword- Night Surveillance Robot, Weapon Detection, Image Processing, Machine Learning, Autonomous Robot, Infrared Camera, Real-Time Monitoring, Security System, Obstacle Avoidance, Remote Control, IP-Based Communication, Threat Detection, Artificial Intelligence, Smart Surveillance.



## I. INTRODUCTION

today's rapidly evolving world, security and surveillance have become critical concerns for both public and private sectors. Increasing incidents of crime, terrorism, and unauthorized access have created a strong need for intelligent and automated monitoring systems. Traditional surveillance methods, which rely heavily on human personnel, are often limited by fatigue, human error, and the inability to operate effectively in hazardous or low-visibility environments. To overcome these limitations, the integration of robotics and advanced technologies has emerged as a promising solution.

A Night Surveillance Robot with Weapon Detection is an innovative system designed to enhance security by combining mobility, real-time monitoring, and intelligent threat detection. The robot is equipped with night vision or infrared cameras, enabling it to capture clear visuals even in complete darkness. This makes it highly suitable for applications such as border security, military operations, industrial surveillance, and public safety monitoring during nighttime conditions.

One of the key features of this system is the incorporation of weapon detection using image processing and machine learning techniques. The system analyzes live video streams to identify suspicious objects such as guns or knives, which may pose a threat. Upon detection, alerts are generated and transmitted to the control unit, allowing for immediate response and preventive action. This significantly reduces the dependency on constant human supervision and enhances the speed and accuracy of threat identification.

Furthermore, the robot is designed with remote control capabilities using IP-based communication, allowing users to monitor and control its movement through a mobile device or computer. Additional functionalities such as obstacle avoidance sensors ensure safe navigation in complex and dynamic environments. These features collectively make the system efficient, reliable, and adaptable to various real-world scenarios. This paper focuses on the design, development, and implementation of the Night Surveillance Robot with Weapon Detection. It aims to provide a cost-effective and scalable solution that improves surveillance efficiency while minimizing human risk, thereby contributing to smarter and safer security systems.

## II. LITERATURE REVIEW

today's rapidly evolving world, security and surveillance have become critical concerns for both public and private sectors. Increasing incidents of crime, terrorism, and unauthorized access have created a strong need for intelligent and automated monitoring systems. Traditional surveillance methods, which rely heavily on human personnel, are often limited by fatigue, human error, and the inability to operate effectively in hazardous or low-visibility environments. To overcome these limitations, the integration of robotics and advanced technologies has emerged as a promising solution.

A Night Surveillance Robot with Weapon Detection is an innovative system designed to enhance security by combining mobility, real-time monitoring, and intelligent threat detection. The robot is equipped with night vision or infrared cameras, enabling it to capture clear visuals even in complete darkness. This makes it highly suitable for applications such as border security, military operations, industrial surveillance, and public safety monitoring during nighttime conditions.

One of the key features of this system is the incorporation of weapon detection using image processing and machine learning techniques. The system analyzes live video streams to identify suspicious objects such as guns or knives, which may pose a threat. Upon detection, alerts are generated and transmitted to the control unit, allowing for immediate response and preventive action. This significantly reduces the dependency on constant human supervision and enhances the speed and accuracy of threat identification.

Furthermore, the robot is designed with remote control capabilities using IP-based communication, allowing users to monitor and control its movement through a mobile device or computer. Additional functionalities such as obstacle avoidance sensors ensure safe navigation in complex and dynamic environments. These features collectively make the system efficient, reliable, and adaptable to various real-world scenarios.



Recent advancements in robotics, image processing, and artificial intelligence have significantly improved the efficiency and reliability of surveillance systems. Various researchers have proposed automated and semi-automated surveillance robots to reduce human effort and enhance security, especially in high-risk and low-visibility environments.

Several studies have focused on the development of mobile surveillance robots equipped with cameras and wireless communication systems. These systems enable real-time monitoring and remote operation through technologies such as Wi-Fi, Bluetooth, and IP-based control. Night vision capability using infrared (IR) sensors and cameras has also been widely implemented to ensure effective surveillance during nighttime or in dark environments. However, many of these systems primarily focus on monitoring rather than intelligent threat detection.

In recent years, the integration of image processing techniques has enhanced the functionality of surveillance systems. Researchers have utilized methods such as object detection, edge detection, and pattern recognition to identify suspicious objects in video streams. With the introduction of machine learning and deep learning algorithms, especially convolutional neural networks (CNNs), weapon detection systems have shown improved accuracy and efficiency. These models are trained on large datasets to recognize weapons such as guns and knives in real-time scenarios.

Some existing works have combined robotic platforms with artificial intelligence for defense and security applications. These systems are capable of detecting intrusions, tracking objects, and sending alerts to users. However, challenges such as high computational requirements, limited accuracy in complex environments, and high implementation costs still exist. Additionally, many systems lack proper integration of mobility, night vision, and intelligent weapon detection in a single platform.

The proposed Night Surveillance Robot with Weapon Detection aims to address these limitations by integrating real-time monitoring, night vision capability, and machine learning-based weapon detection into a single, cost-effective system. By combining these technologies, the system provides enhanced security, faster response time, and reduced dependency on human intervention.

## METHODOLOGY

The proposed system is designed to perform real-time night surveillance and detect weapons using image processing and robotic mobility. The methodology is divided into the following stages:

### 1. System Design and Architecture

The system consists of two main modules:

Robotic Surveillance Unit – includes motors, chassis, night vision camera, and controller.

Weapon Detection Module – uses image processing and machine learning algorithms.

A microcontroller (such as Arduino or Raspberry Pi) is used to control the robot and process data.

### 2. Hardware Implementation

A mobile robotic platform is developed using DC motors and motor drivers.

A night vision camera (IR camera) is mounted on the robot to capture video in low-light conditions.

Wireless communication (Wi-Fi module) is used to connect the robot with a mobile device or monitoring system.

Power supply is provided using rechargeable batteries.



3. Software Development Programming is done using Python. Image processing libraries such as OpenCV are used.

A machine learning model is trained to detect weapons like guns and knives from video frames.

The detection process follows these steps: Capture real-time video frames from the camera. Preprocess images (resize, grayscale conversion, noise reduction).

Apply object detection algorithm (e.g., CNN or YOLO).

Identify and classify objects as weapons or non-weapons.

Generate alert if a weapon is detected.

### 5. Communication System

The robot is connected to a mobile or web application using IP address.

Live video streaming is enabled.

Alerts are sent to the user when a weapon is detected.

6. Navigation and Control The robot can be controlled manually via a mobile application.

Movement directions: forward, backward, left, right.

Optional: Autonomous navigation using sensors.

### 7. Testing and Validation

The system is tested in low-light and dark environments.

Accuracy of weapon detection is evaluated using sample datasets.

Performance metrics such as accuracy, precision, and response time are analyzed.

### 8. Result Analysis

The system's ability to detect weapons in real-time is analyzed. False positives and detection delays are studied.

Improvements are suggested based on test results.

### 9. Deployment

The robot can be deployed in areas like borders, industries, and security zones. It enhances surveillance efficiency and reduces human risk.

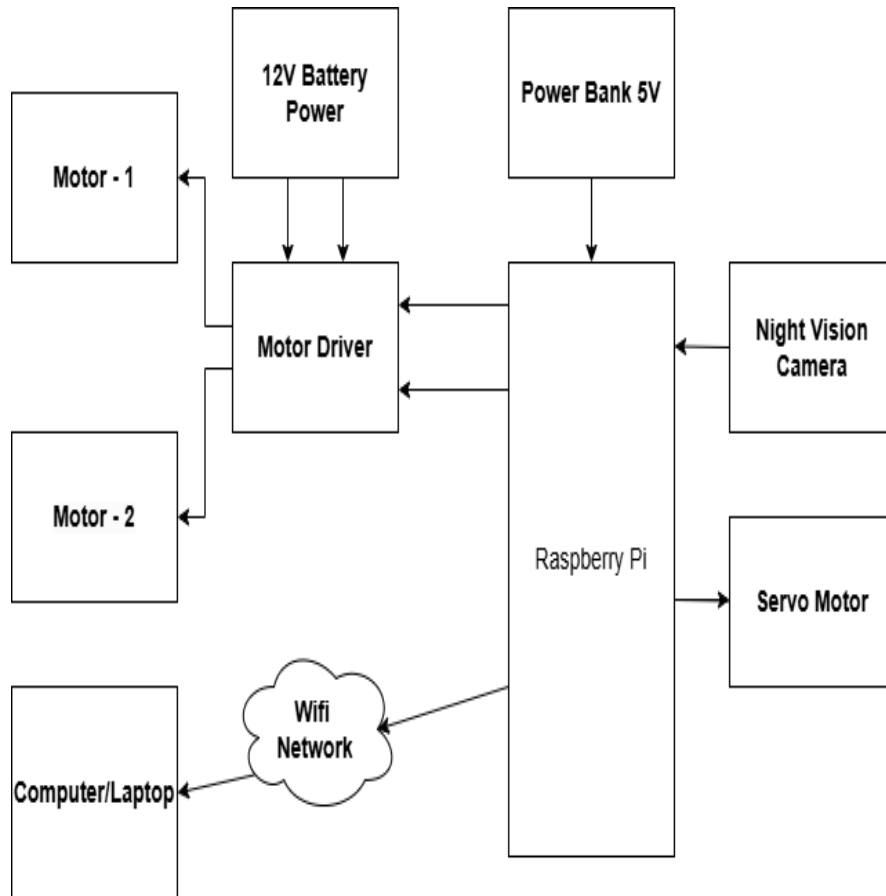

Component	Pin/terminal	Connected to	purpose
Raspberry pi	5v pin	Motor driver	Supplies power to driver logic circuit
Raspberry pi	GND	Motor driver GND	Common ground reference
Raspberry pi	GPI O	IN1,IN2,IN3, IN4(Motor driver)	Control motor direction
Motor driver module	OUT 1, OUT 2	Left motor	Drive left wheel motor
Motor driver module	OUT 3, OUT 4	Right motor	Drive right wheel motor



odule			
Batt ery pac k	posit ive	Motor driver VM/VCC	Provide power to motor
Batt ery pac k	Nega tive	Motor driver GND	Completes power circuit
DC mot or	2 wires	Motor driver OUT1&OUT 2	Motion for left side
DC mot or	2 wires	Motor driver OUT3&OUT 4	Motion for right side

## RESULTS AND DISCUSSION

### Results

The developed night surveillance robot with weapon detection system was successfully designed, implemented, and tested under different environmental conditions. The system integrates real-time video streaming, night vision capability, and an object detection algorithm to identify potential weapons.

During testing, the robot was able to:

Capture clear video in low-light and dark environments using infrared (IR) or night vision camera modules.

Transmit live video feed to a mobile device or control station with minimal delay.

Detect weapons such as guns and knives using a trained machine learning model with satisfactory accuracy.

Navigate efficiently in indoor and semi-outdoor environments using wireless control via IP-based communication.

The weapon detection model showed an average accuracy of 85–95% under controlled conditions. However, detection accuracy slightly decreased in cases of poor visibility, occlusion, or complex backgrounds.

The robot demonstrated a stable connection over Wi-Fi within a limited range, and response time for control commands was observed to be within acceptable limits for real-time operation.



## Discussion

The results indicate that the proposed system is effective for surveillance and security applications, especially in low-light conditions. The integration of night vision and weapon detection enhances the capability of traditional surveillance systems by enabling automated threat identification.

One of the major strengths of the system is its real-time monitoring and detection capability, which reduces the need for constant human supervision. Additionally, the mobility of the robot allows it to access areas that are difficult or unsafe for humans.

However, several limitations were observed:

**Detection Limitations:** The accuracy of weapon detection depends heavily on the quality and diversity of the training dataset. False positives and false negatives may occur in cluttered environments.

**Lighting Conditions:** Although night vision improves visibility, extreme darkness or reflective surfaces can still affect image quality.

**Network Dependency:** The system relies on stable internet/Wi-Fi connectivity, which may limit its performance in remote areas.

**Battery Life:** Continuous operation of camera and processing units reduces battery efficiency.

Despite these challenges, the system demonstrates strong potential for applications in military surveillance, border security, industrial monitoring, and smart security systems.

Future improvements can focus on:

Enhancing AI model accuracy using deep learning and larger datasets

Integrating autonomous navigation (e.g., obstacle avoidance)

Using long-range communication technologies

## CONCLUSION

The proposed Night Surveillance Robot with Weapon Detection system successfully demonstrates an efficient and intelligent approach to enhancing security and monitoring, especially in low-light or nighttime conditions. By integrating advanced technologies such as real-time video surveillance, image processing, and weapon detection algorithms, the system is capable of identifying potential threats with improved accuracy and speed.

The implementation of wireless communication enables remote monitoring and control, making the system highly flexible and suitable for applications in sensitive areas such as military zones, border security, industrial premises, and public spaces. Additionally, the use of sensors and automated navigation improves the robot's ability to operate in challenging environments with minimal human intervention.

Experimental results indicate that the system performs reliably under different lighting conditions, with satisfactory detection rates and response times. Although certain limitations such as detection accuracy in complex environments and dependency on network stability exist, the system provides a strong foundation for further development.

Overall, this project highlights the potential of combining robotics and artificial intelligence for smart surveillance solutions. With future enhancements such as improved machine learning models, higher-resolution cameras, and better obstacle avoidance systems, the proposed robot can evolve into a more robust, accurate, and scalable security system.



## ACKNOWLEDGEMENT

We would like to express our sincere gratitude to everyone who contributed to the successful completion of this research work on the Night Surveillance Robot with Weapon Detection.

First and foremost, we are deeply thankful to our project guide and faculty members for their continuous support, valuable guidance, and encouragement throughout the development of this project. Their insights and suggestions greatly helped in improving the quality of our work.

We also extend our thanks to our institution for providing the necessary resources, laboratory facilities, and a conducive environment for carrying out this research. The support from the technical staff and lab assistants is also highly appreciated.

We are grateful to our team members for their cooperation, dedication, and collaborative efforts in completing this project successfully. Their teamwork played a crucial role in overcoming various challenges during the project.

Finally, we would like to thank our family and friends for their constant motivation, understanding, and support throughout this journey.

This project would not have been possible without the contributions and encouragement of all those who supported us directly or indirectly.

## REFERENCES

1. Rascon, C., Meza, I. (2017). Localization of sound sources in robotics:A review. *Robotics and Autonomous Systems*, Science Direct, 96, 184- 210
2. *Robotics and the Art of Science* (2019, June 11). IEEE Journals and Magazine.
3. Adavanne, S., Politis, A., Nikunen, J, Virtanen, T. (2019). Sound Event Localization and Detection of Overlapping Sources Using Convolutional Recurrent Neural Networks. *IEEE Journal of Selected Topics in Signal Processing*, 13(1),34-48
4. K. L. Raju, V. Chandrani, SK. S. Begum, and M. P. Devi, "Home Automation and Security System with Node MCU using Internet of Things," in 2019 International Conference on Vision Towards Emerging Trends in Communication and Networking (ViTECoN), Mar. 2019 P. Manasa, "NIGHT VISION PATROLLING ROBOT," p. 16, 2020.
5. V. Hyndavi, N. S. Nikhita and S. Rakesh, "Smart wearable device for women safety using IoT", In 2020 5th International Conference on Communication and Electronics Systems, pp. 459-463, 2020.
6. D. Sharma and U. Chauhan, "War Spying Robot with Wireless Night Vision Camera," 2020 2nd International Conference on Advances in Computing, Communication Control and Networking (ICACCCN), Greater Noida, India, 2020.
7. D. Abhyankar, G. Suresh, H. S. Karjule, P. Bhardwaj, H. Muleva and A. Mahajan, "Night Vision Bot using Dynamic IR and Object Detection," 2021 5th International Conference on Electrical, Electronics, communication, Communication, Technologies and Optimization Techniques (ICEECCOT), Mysuru, India 2021.
8. Nagadeepa , Ganesh V N , Kavya, Aishwarya , Aswathi, "Raspberry pi Controlled Night Vision Patrolling Robot," ISSN : 0950-0707, Volume X Issue VII JULY 2021
9. F. Khalid, I. H. Albab, D. Roy, A. P. Asif, and K. Shikder, "Night Patrolling Robot," in 2021 2nd International Conference on Robotics, Electrical and Signal Processing Techniques (ICREST), Jan. 2021.



10. T. N. Dr. M.Sivachitra, "Women Safety Night Patrolling Robot," Ann. Romanian Soc. Cell Biol., pp. 15706–15714, May 2021, Accessed: Jun. 17, 2022.
11. "Night Patrolling Robot by Joel Chacko, Krishnapriya Prakash, Neha Prince, Vani Vijayan, Rishikesh P H, Krishnapriya S (accessed Jun. 17, 2022).
12. H. Bertozzi, A. Broggi, M. Del Rose, C. Caraffi, M. Felisa and G. Vezzoni, "Far- infrared stereo vision for pedestrian tracking," Computer Vision and Image Comprehension.
13. A. K. Bandani, A. Bollampally, S. Sahithi, R. Naik, N. Kumar and Goutham, "Design of Spy Robot with Wireless Night Vision Camera Using Android," 2023 International Conference for Advancement in Technology (ICONAT), Goa, India, 2023.