



# Smart Energy Optimization of Hybrid Renewable System Using Iot and Storage Technology

Prof S.Jaichitra<sup>1</sup>, M.Dhinakaran<sup>2</sup>, P.Praveenkumar<sup>3</sup>, S.Pradap<sup>4</sup>, S.Priyanka<sup>5</sup>

<sup>1</sup>Assistant Professor, Department of Electrical and Electronics Engineering,  
JAYALAKSHMI INSTITUTE OF TECHNOLOGY, THOPPUR.

<sup>2,3,4,5</sup> UG Students, Department of Electrical and Electronics Engineering,  
JAYALAKSHMI INSTITUTE OF TECHNOLOGY, THOPPUR.

## How to Cite this Article:

M.Dhinakaran, P.Praveenkumar, S.Pradap, & S.Priyanka, (2026). Smart Energy Optimization of Hybrid Renewable System Using Iot and Storage Technology. International Journal of Creative and Open Research in Engineering and Management, <i>02</i>(04).  
<https://doi.org/10.55041/ijcope.v2i3.274>

## License:

This article is published under the terms of the Creative Commons Attribution 4.0 International License (CC BY 4.0), which permits unrestricted use, distribution, and reproduction in any medium, provided the original author(s) and the source are credited.

© The Author(s). Published by International Journal of Creative and Open Research in Engineering and Management.



<https://doi.org/10.55041/ijcope.v2i3.274>

## ABSTRACT

This project deals with the design and development of a smart energy optimization system using a hybrid renewable energy source with battery storage and IoT monitoring. The system mainly uses solar energy to generate electrical power. The enerated energy is efficiently stored in a battery through an MPPT charge controller, which helps in improving charging efficiency and maintaining stable power supply.

An ESP32 microcontroller is used to monitor important parameters such as voltage and current with the help of sensors. The collected data is transmitted to an IoT platform through Wi-Fi for real-time monitoring using a mobile or web application. This allows the user to track system performance from anywhere.

## INTRODUCTION

Solar energy systems are widely used to reduce dependency on the utility grid.

Integrating solar with the grid improves energy efficiency and reduces electricity cost.

□ This project presents a smart energy management system that combines solar power with the power grid using IoT technology. The system automatically switches between solar and grid power based on availability and load demand. Solar and grid integrated systems are useful in homes and industries where continuous power is required. IoT monitoring helps in efficient energy usage, reduces power loss, and ensures reliable power supply. control mechanisms can enhance performance, flexibility, and user convenience.



To overcome these challenges, hybrid renewable energy systems are developed by combining multiple energy sources, such as solar and wind, to ensure continuous power generation. In addition, energy storage systems, such as batteries, play a crucial role in storing excess energy generated during peak conditions and supplying power during low generation periods. With advancements in technology, the integration of the Internet of Things (IoT) has significantly improved the performance and management of renewable energy systems. IoT enables real-time monitoring, data collection, remote access, and intelligent control of energy systems. By using sensors and microcontrollers, system parameters like voltage, current, temperature, and battery status can be continuously monitored and analyzed.

This project focuses on the design and implementation of a smart energy optimization system that integrates hybrid renewable energy sources with IoT and storage technology. The goal is to enhance energy efficiency, ensure reliable power supply, and minimize energy wastage through intelligent monitoring and control

## Literature Review

Recent advancements in renewable energy systems have focused on improving efficiency and reliability through the integration of smart technologies. Many researchers have proposed IoT-based energy management systems to monitor and control power usage in real-time.

These systems utilize sensors and cloud platforms to collect and analyze data, enabling better decision-making and reduced energy wastage. Studies on solar and grid integrated systems highlight that combining renewable energy with the utility grid ensures continuous power supply even during low generation periods.

Additionally, the use of battery storage systems has been widely discussed to store excess energy and provide backup during power shortages. Research also shows that IoT-enabled monitoring improves system performance, enhances user control through mobile applications, and supports the development of smart grid infrastructure.

Overall, the combination of hybrid renewable energy, storage technology, and IoT plays a vital role in achieving efficient, reliable, and sustainable energy management systems.

### 1. Hardware

The hardware components used in this project are essential for generating, controlling, monitoring, and displaying the energy system. The main hardware includes a solar panel for power generation, an MPPT charge controller to improve efficiency, and a battery for energy storage. A 12V to 230V inverter is used to convert DC power into AC supply for operating loads.

An ESP32 microcontroller is used as the main controller to manage system operations. Voltage and current sensors are used to measure electrical parameters in real-time. A relay switch is used for automatic switching between solar power and the utility grid supply. The system also includes a 16x2 LCD display to show real-time values such as voltage, current, and power.

Additionally, a power adaptor is used to supply power to the controller, and connecting wires are used for circuit connections. All components are mounted on an acrylic sheet for proper structure and safety.



## BLOCK DIAGRAM:

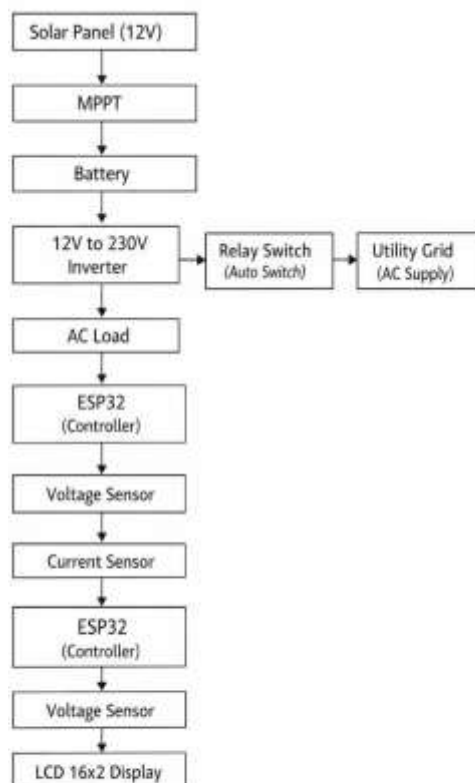

## Software

The software component is responsible for acquiring gesture data, processing it into control commands, transmitting it via RF communication, and enabling IoT-based monitoring and control. It integrates embedded programming, communication protocols, and cloud platforms.



The system is typically developed using:

- Arduino IDE

Used to write, compile, and upload code to microcontrollers like Arduino, ESP8266, or ESP32.

- C++

Primary language for embedded system programming.

The system starts with a solar panel (12V) which generates electrical energy from sunlight. This energy is passed to the MPPT (Maximum Power Point Tracking) controller, which improves the efficiency of power generation by extracting maximum power from the solar panel.

The output from the MPPT is stored in the battery, which acts as an energy storage unit. The stored DC power is then converted into AC power using a 12V to 230V inverter so that it can be used for AC loads.

A relay switch (automatic switch) is used to select between solar power and the utility grid supply. When solar power is available, the system uses it; otherwise, it automatically switches to the grid to ensure continuous power supply.

The AC load receives power from either the solar system or the grid. The ESP32 controller is used to monitor and control the entire system operation.

**Voltage and current sensors** are connected to measure electrical parameters such as voltage and current in real-time. These values are processed by the ESP32.

Finally, the measured data is displayed on a **16x2 LCD display**, allowing the user to monitor system performance. The ESP32 can also send data to a mobile device using IoT for remote monitoring.

## CONCLUSION AND FUTURE WORK

This project successfully demonstrates a smart energy optimization system using solar power integrated with the utility grid, IoT, and storage technology. The system efficiently manages energy by automatically switching between solar and grid supply based on availability. Real-time monitoring using sensors and the ESP32 controller ensures accurate measurement of electrical parameters such as voltage and current. The data is displayed on an LCD and can also be accessed through a mobile device, enabling remote monitoring. Overall, the system improves energy efficiency, reduces dependency on conventional power sources, and ensures a reliable and continuous power supply.

The proposed system can be further enhanced by integrating advanced technologies to improve efficiency and performance. Future improvements may include the implementation of an advanced battery management system to increase storage life and efficiency. Artificial intelligence and machine learning techniques can be applied to predict energy generation and optimize power usage more effectively. The system can also be expanded by adding other renewable energy sources such as wind energy to form a more robust hybrid system. Additionally, a dedicated mobile application with advanced control features can be developed for better user interaction and remote operation. Further enhancements in safety features, fault detection, and scalability can make the system suitable for large-scale smart grid and industrial applications.



## References

1. A. K. Saxena and V. Dutta, "Grid Connected Solar PV System for Efficient Power Generation," IEEE Transactions on Energy Conversion, vol. 34, no. 2, pp. 765–772, 2019.
2. S. Chowdhury, S. P. Chowdhury, and P. Crossley, Microgrids and Active Distribution Networks, IET Press, 2009.
3. M. A. Hannan et al., "IoT-Based Smart Energy Monitoring System for Grid Applications," IEEE Access, vol. 7, pp. 123–130, 2020.
4. J. A. Duffie and W. A. Beckman, Solar Engineering of Thermal Processes, 4th ed., Wiley, 2013.
5. T. Eswam and P. L. Chapman, "Comparison of Photovoltaic Array Maximum Power Point Tracking Techniques," IEEE Transactions on Energy Conversion, vol. 22, no. 2, pp. 439–449, 2007.
6. N. Mohan, T. Undeland, and W. Robbins, Power Electronics: Converters, Applications, and Design, 3rd ed., Wiley, 2003.
7. R. H. Lasseter, "Smart Distribution: Coupled Microgrids," Proceedings of the IEEE, vol. 99, no. 6, pp. 1074–1082, 2011.
8. B. Singh and V. Bist, "Power Quality Improvement in Grid-Connected Solar Systems," IEEE Transactions on Industry Applications, vol. 51, no. 4, pp. 3200–3208, 2015.