



# Analysis of Hybrid Energy Storage System for EV Battery Charging System in PSIM

<sup>1</sup>Pratibha Kumari, Shweta Raj, <sup>3</sup>Sachindra Kumar Verma

<sup>1</sup>M.Tech Scholar, NRI Institute of Research and Technology, Bhopal (M.P.), INDIA,

Mail id- pratibhak051995@gmail.com@gmail.com

<sup>2</sup>Assistant Professor, NRI Institute of Research and Technology, Bhopal (M.P.), INDIA,

Mail id-drshwetarajnri@gmail.com

<sup>3</sup>Assistant Professor, NRI Institute of Research and Technology, Bhopal (M.P.), INDIA,

Mail id-skvme19@gmail.com

## How to Cite this Article:

Kumari, P. & Verma, S. K. (2026). Analysis of Hybrid Energy Storage System for EV Battery Charging System in PSIM. International Journal of Creative and Open Research in Engineering and Management, <i>02</i>(05).  
<https://doi.org/10.55041/ijcope.v2i5.764>

## License:

This article is published under the terms of the Creative Commons Attribution 4.0 International License (CC BY 4.0), which permits unrestricted use, distribution, and reproduction in any medium, provided the original author(s) and the source are credited.

© The Author(s). Published by International Journal of Creative and Open Research in Engineering and Management.



<https://doi.org/10.55041/ijcope.v2i5.764>

## ABSTRACT

The transition to electric vehicles (EVs) demands advanced energy storage systems capable of addressing the growing requirements for efficiency, reliability, and sustainability. This study presents the development of a Hybrid Energy Storage System (HESS) designed for EV battery charging, integrating lithium-ion batteries and supercapacitors. By leveraging the high energy density of lithium-ion batteries and the rapid charge-discharge capabilities of supercapacitors, the proposed HESS addresses the limitations of individual storage technologies. The hybrid system architecture optimizes energy flow, minimizes power losses, and ensures a seamless transition between energy sources. Key design aspects, including energy management strategies, control algorithms, and system integration, are discussed in detail. Experimental validation highlights significant enhancements in charge/discharge cycles, energy efficiency, and thermal stability compared to conventional battery systems. Beyond technical performance, the study evaluates the economic and environmental impacts of HESS adoption in EVs. The findings indicate reduced operational costs and lower carbon emissions, reinforcing the role of HESS in promoting sustainable transportation. The proposed solution not only extends the lifespan of EV battery systems but also supports the development of a more robust EV charging infrastructure. This work underscores the

potential of HESS as a transformative approach to addressing the challenges of energy storage in electric vehicles, contributing to the advancement of cleaner, more efficient, and cost-effective transportation solutions.



## 1. Introduction

The rapid global shift toward sustainable transportation has positioned electric vehicles (EVs) at the forefront of the automotive revolution. EVs, powered by clean energy sources, promise to mitigate greenhouse gas emissions and reduce dependence on fossil fuels [1]. However, the efficiency and widespread adoption of EVs are closely tied to advancements in energy storage systems. The key challenges in EV battery technology, such as limited range, long charging times, and performance degradation, have driven the search for innovative solutions to enhance energy storage capabilities. In this context, the development of Hybrid Energy Storage Systems (HESS) has emerged as a promising approach to address the limitations of conventional storage technologies [2]. A HESS combines two or more energy storage technologies to leverage their complementary strengths while mitigating their individual weaknesses. For EV battery charging applications, lithium-ion batteries and super capacitors are often the preferred components of a hybrid system due to their distinct and synergistic properties [3]. Lithium-ion batteries offer high energy density, making them suitable for extended driving ranges. However, their relatively slower charge-discharge rates and susceptibility to thermal issues can limit their performance. In contrast, super capacitors excel in rapid charge-discharge cycles and exhibit excellent thermal stability, but their lower energy density makes them unsuitable as standalone storage solutions. By integrating these two technologies, a HESS can provide enhanced energy management, increased efficiency, and prolonged battery lifespan.

The architecture of a HESS is crucial for its performance in EV battery charging applications. A well-designed system ensures optimal energy flow between lithium-ion batteries and supercapacitors, dynamically allocating energy to meet the instantaneous demands of the EV [4]. For instance, during acceleration or regenerative braking, supercapacitors can handle high power demands or surges, reducing the strain on lithium-ion batteries. Similarly, during steady-state driving, lithium-ion batteries can supply energy at a stable rate, while supercapacitors remain on standby [5]. This dynamic energy-sharing mechanism enhances the overall reliability, efficiency, and durability of the storage system.

One of the critical aspects of HESS development is the implementation of advanced energy management strategies. These strategies involve real-time monitoring and control algorithms that optimize the interaction between storage components. Techniques such as state-of-charge (SOC) balancing, power distribution algorithms, and predictive control models play a pivotal role in maximizing system efficiency [6]. Additionally, innovative thermal management systems are integrated into the architecture to ensure safe and stable operation under varying conditions.

Beyond technical performance, the adoption of HESS for EV battery charging has significant economic and environmental implications. From an economic perspective, HESS can reduce operational costs by improving energy efficiency and minimizing wear and tear on lithium-ion batteries. By extending the lifespan of batteries, HESS lowers the frequency of replacements, thus reducing the overall cost of ownership for EV users. Environmentally, the use of HESS can contribute to a decrease in carbon emissions by optimizing the use of renewable energy sources for charging and minimizing energy losses. Moreover, the ability of HESS to support fast-charging infrastructure aligns with the increasing demand for convenient and efficient EV charging solutions [7].

This study explores the design, implementation, and evaluation of a HESS tailored for EV battery charging. The proposed system integrates lithium-ion batteries and supercapacitors, focusing on enhancing charge-discharge cycles, thermal stability, and overall efficiency. The architecture incorporates advanced control algorithms and energy management strategies to optimize performance. Experimental results demonstrate the



superiority of HESS compared to conventional battery systems, with notable improvements in energy efficiency, thermal stability, and charge-discharge reliability [8].

## 2. Methodology

The development of an efficient architecture for a hybrid energy system tailored for electric vehicle (EV) battery charging involves a multi-step approach encompassing the integration of various energy storage technologies, designing a control system for power flow, and ensuring optimal performance [9]. The aim is to create a system that can meet the high power demands of EV charging stations while maintaining energy efficiency and stability [10]. This methodology outlines the systematic steps and considerations in designing, simulating, and testing such a hybrid energy system (HES). A hybrid energy storage system (HESS) integrates multiple energy storage technologies, each offering unique strengths in terms of power density, energy density, and response time. The primary goal of an HESS is to provide a balanced energy flow, meeting the varying demands of EV charging stations. This system typically combines high-energy storage devices, like batteries, with high-power storage devices, such as super capacitors [11]. The architecture of the HESS is designed to optimize energy transfer between the energy sources and the EV batteries, ensuring that the charging process is efficient and sustainable. Figure 2.1 presents the block diagram of hybrid energy storage system.

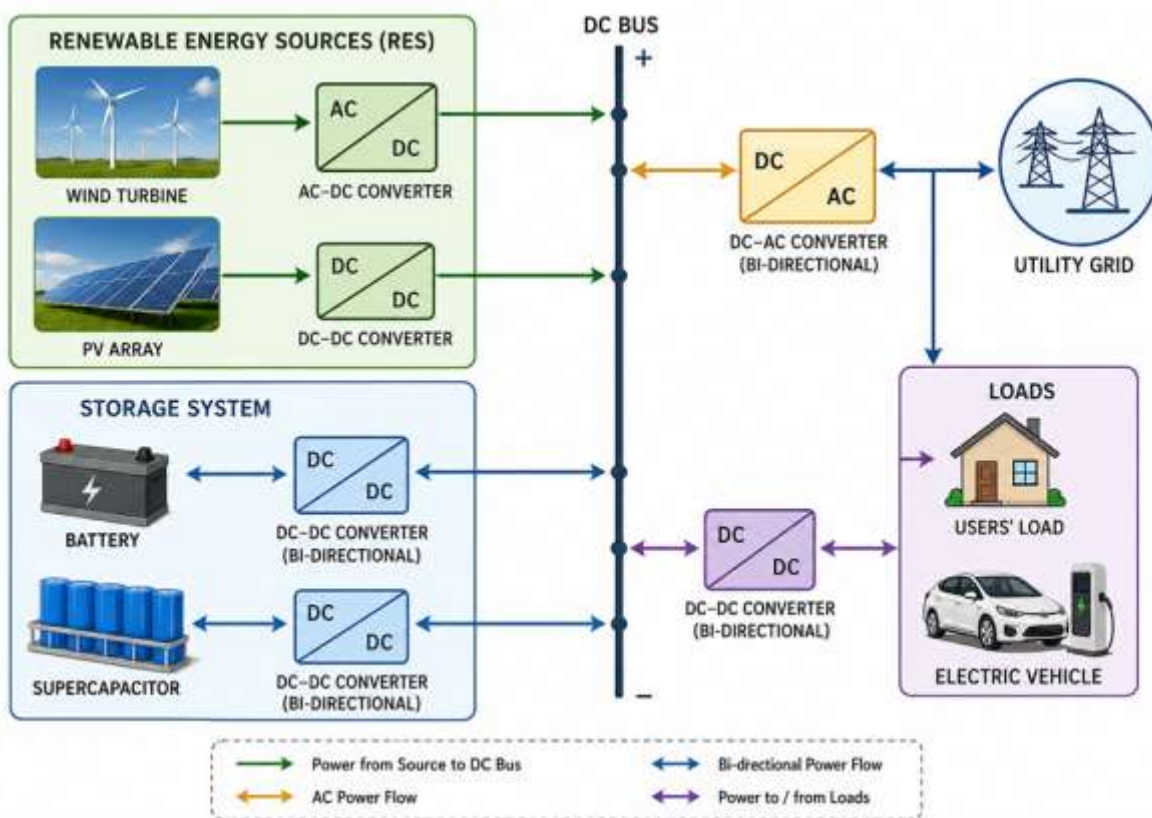


Figure 2.1 Structure of Hybrid Energy Storage System.

### 2.1. System Design and Configuration

- **Battery Selection:** Choose the primary energy storage unit, such as lithium-ion batteries, for their high energy density and suitability for extended storage of energy. Lithium-ion batteries are ideal for providing sustained energy output during EV charging sessions.



- **Super capacitor Integration:** Super capacitors, known for their high power density and rapid charge-discharge capabilities, are selected as a secondary storage unit. They help manage short-term power spikes during the initial charging phase of EVs.
- **Hybrid Configuration:** Determine the most effective configuration for integrating these technologies, such as parallel or series arrangements, to balance energy and power needs. The chosen configuration should leverage the high energy density of batteries and the fast-response capabilities of super capacitors [12].

## 2.2. Power Electronics and Interface Design

- **Converter Design:** Develop a power electronics interface using DC-DC converters to manage energy flow between the hybrid energy storage system and the EV charging station. This includes:
  - **Bidirectional DC-DC Converters:** Enable energy flow between batteries and the charging system for controlled charging and discharging.
  - **Buck-Boost Converters:** Manage voltage levels between supercapacitors and the load, ensuring consistent voltage output during transient power demands.
- **Design of DC Bus:** Integrate a DC bus that acts as a common interface between the various energy storage components and the EV charger. The DC bus allows multiple storage units to operate simultaneously and balance energy exchange efficiently.

## 2.3. HESS Architecture

The architecture of a hybrid energy storage system for EV battery charging includes several critical components:

- **Primary Energy Storage Unit (Battery):** This unit is usually composed of lithium-ion batteries due to their high energy density and long-term storage capabilities. Lithium-ion batteries can store a significant amount of energy and discharge it over a prolonged period, making them ideal for providing sustained power during the charging of EV batteries.
- **Secondary Energy Storage Unit (Super capacitors):** Super capacitors are integrated into the HESS to complement the batteries. Unlike batteries, super capacitors offer high power density, which allows them to deliver energy quickly and handle rapid charge and discharge cycles. This makes them suitable for managing power surges and short-term energy needs during the initial phase of EV charging or during peak power demand.
- **Power Electronics Interface:** Power converters, such as DC-DC and DC-AC converters, are crucial for managing the energy flow between the different storage units and the EV battery. They adjust the voltage and current to match the charging requirements of the EV battery, ensuring efficient energy transfer.
- **Control System:** The control system is responsible for the optimal management of energy flow within the HESS. It monitors the state of charge (SOC) of each storage unit and directs energy between batteries, super capacitors, and the EV charging station according to real-time demand. This system includes algorithms for energy management, load balancing, and power distribution, enabling smooth operation[13].

## 2.4. Energy Storage Integration

- **Parallel Configuration:** In many HESS designs, batteries and super capacitors are connected in parallel to a common DC bus. This allows both storage units to simultaneously supply energy to the load or receive energy during charging. The parallel configuration helps in balancing the energy flow and managing the



power demands efficiently. The batteries provide a stable energy supply, while the super capacitors handle power fluctuations.

- **Series Configuration:** In certain designs, batteries and super capacitors are connected in series with appropriate converters to manage their individual voltage levels. This configuration is used when the voltage levels of the storage devices need to be matched or adjusted before being supplied to the EV charger. Series configurations can simplify control strategies but may require more sophisticated power management [14].

### 3. Simulation of Proposed System

#### 3.1. System Design Components in PSIM

- **Solar PV Array:**
  - In PSIM, you can model the solar PV system using a controlled DC source. The output current and voltage can be varied using a lookup table or a time-varying function to mimic changes in solar irradiance.
  - Use a **Boost Converter** to step up the voltage from the PV system before connecting it to the DC bus.
- **Wind Energy System:**
  - Model the wind turbine and generator (typically a **Permanent Magnet Synchronous Generator (PMSG)**) with a rectifier circuit.
  - Connect the wind energy to the DC bus using a **rectifier** and possibly a **Boost Converter** to manage the voltage levels.

#### 3.2. Hybrid Energy Storage System (HESS)

A hybrid energy storage system typically includes:

- **Battery Storage** (e.g., Lithium-ion or Lead-acid battery).
- **Supercapacitors** for fast energy discharge.

In PSIM, you can model these components using predefined blocks or custom parameter inputs:

- **Battery Model:**
  - PSIM has built-in models for batteries, which allow you to define key parameters like nominal voltage, capacity, state of charge (SoC), and internal resistance.
  - The battery is connected to the DC bus through a **Bidirectional DC-DC Converter**, which allows the battery to charge or discharge depending on the system needs.
- **Ultra capacitor Model:**
  - PSIM also provides a Ultra capacitor model where you can define the voltage, capacitance, and equivalent series resistance (ESR).
  - The Ultra capacitor will also be connected via a **Bidirectional DC-DC Converter** to allow it to charge and discharge as needed to handle high power demands or transient loads.

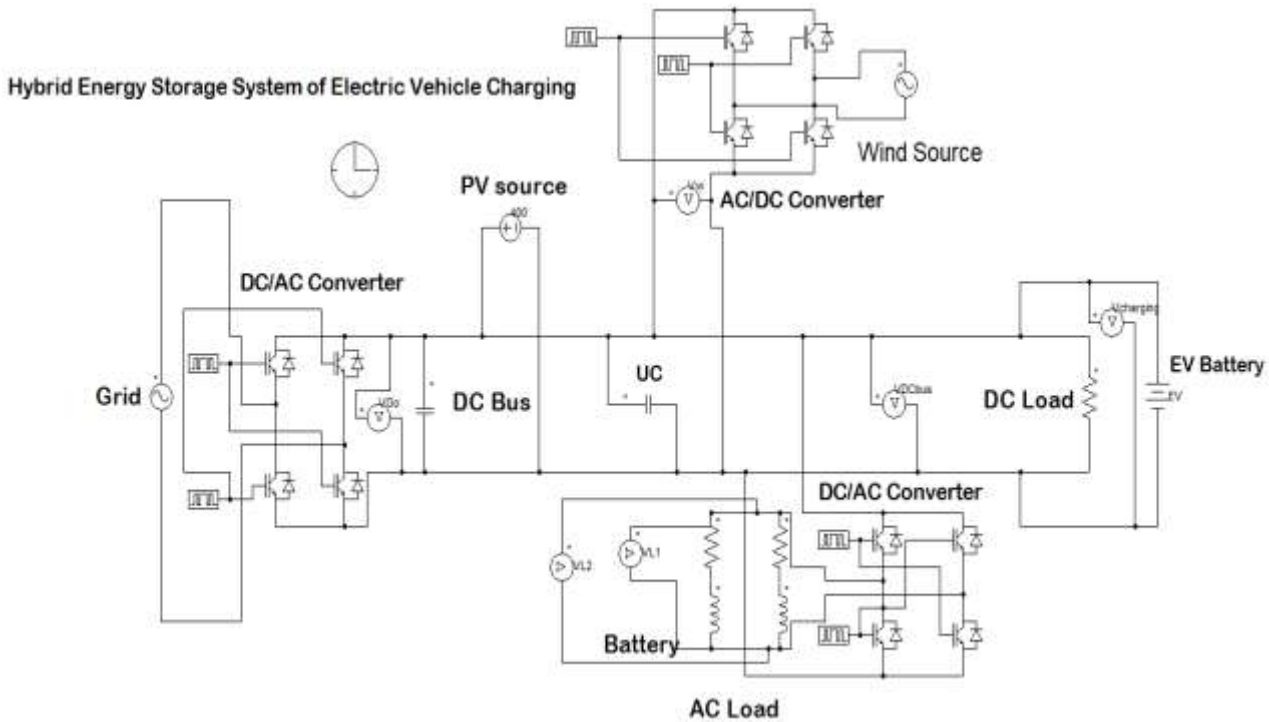
#### 3.3. EV Battery Charging System

The EV battery is typically modeled using PSIM's battery component:

- Set up the EV battery's charging profile (e.g., **Constant Current/Constant Voltage (CC/CV)** charging method).



- Use a **Buck Converter** between the DC bus and the EV battery to regulate the charging voltage and current.



**Figure 3.1: Circuit Diagram of proposed HESS for EV charging**

Simulating the Hybrid Energy Storage System for EV Battery Charging in PSIM involves careful design of the power electronics circuits, implementation of control strategies, and analysis of performance under various conditions. With PSIM's powerful simulation capabilities, you can model the dynamic interactions between renewable energy, storage, and load, ensuring an efficient and reliable system for EV charging. The simulation parameters are presented in table 3.1.

**Table 3.1. Simulation Parameters**

S.No.	Component	Specifications
1.	PV source	400V
1.	Grid Voltage	Peak Voltage 110 V, f=50 HZ
2.	Super capacitor	10 micro farad
4.	Battery Charging voltage	400 V
1.	Power electronics switch	IGBT (ideal)
2.	Switching Frequency	5kHz



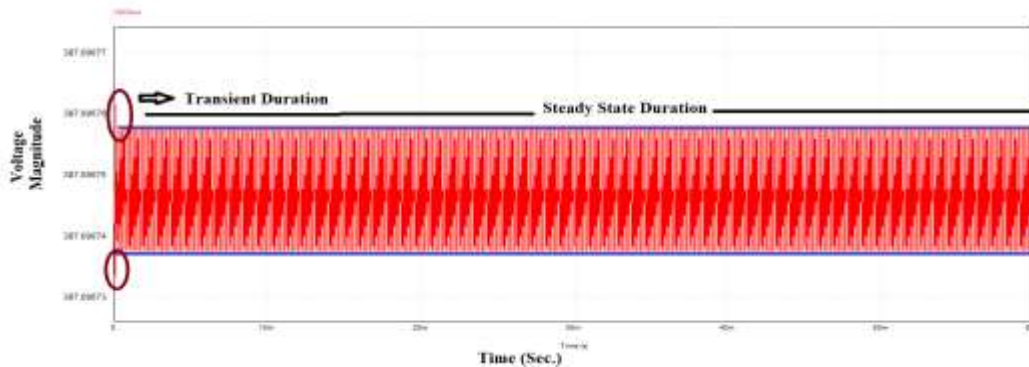
## 4.Result & Discussions

The PSIM simulation provides a detailed performance analysis of the hybrid energy storage system under varying operational conditions, helping to refine and validate the design for reliable energy delivery to rural areas.

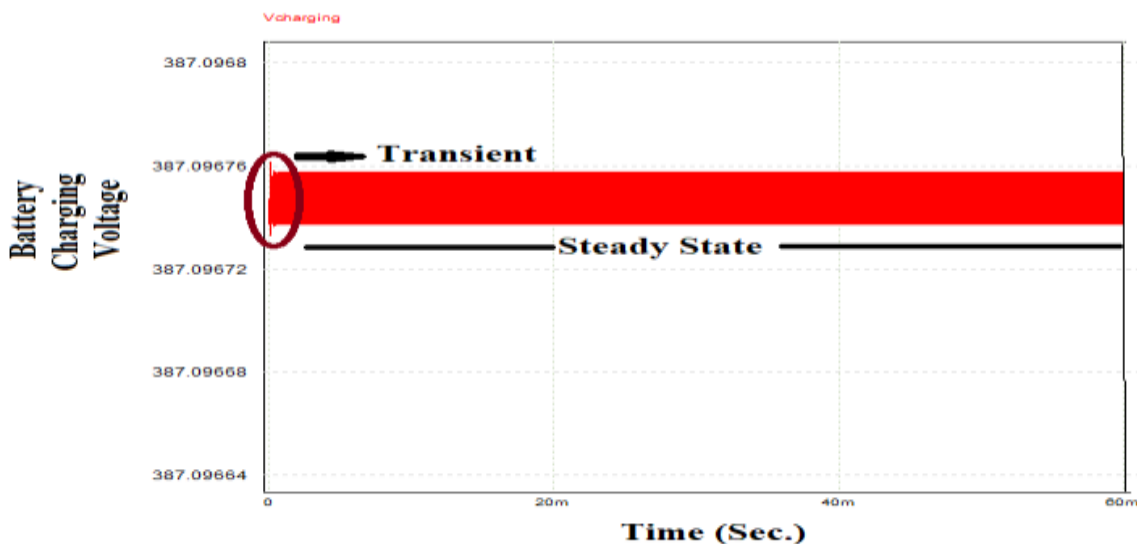
### 4.1. Results of Battery Charging Unit without Grid Connected

- **Battery Charging Voltage**

**Figure 4.1:** demonstrates the battery charging voltage profile powered exclusively by the proposed hybrid energy system. Following an initial transient period, the voltage stabilizes at approximately 387 volts, with negligible variations ranging from 387.09694 to 387.0968 volts, ensuring consistent charging efficiency

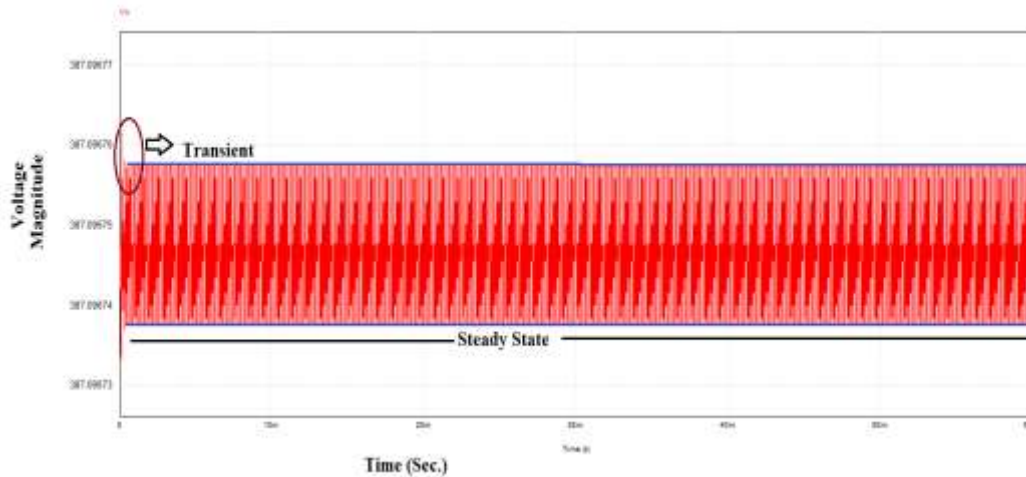


**Figure 4.1** Battery charging Voltage Profile without Grid connection



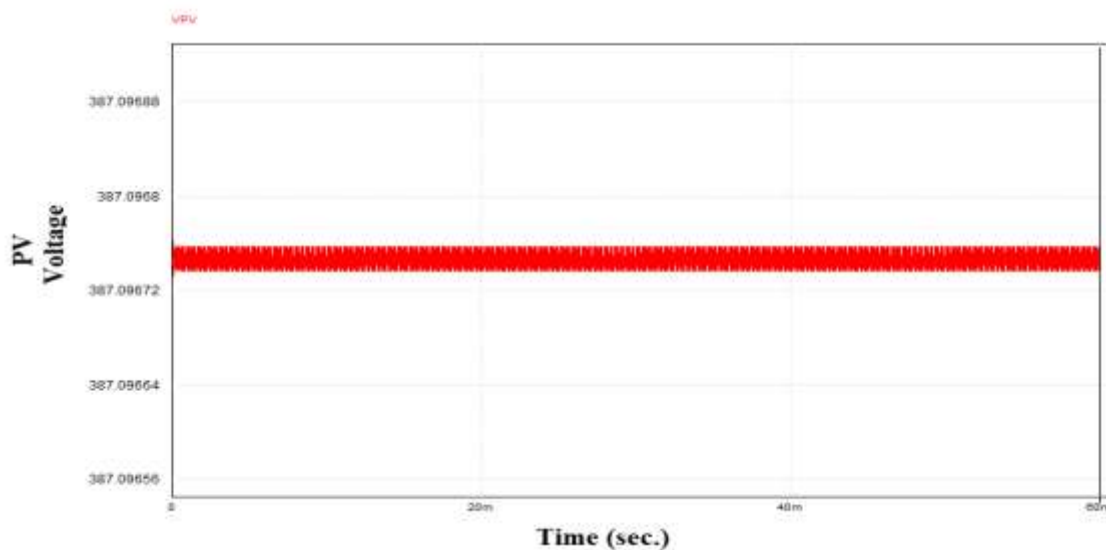
**Figure 4.2.** Magnitude of Battery Charging Voltage without Grid Connection

**Figure 4.2** highlights the precise regulation of the battery charging voltage, emphasizing the system's ability to maintain a steady and reliable voltage output without reliance on the grid.



**Figure 4.3. Voltage Level Of Wind Turbine Output**

**Figure 4.3** shows the output voltage of the wind turbine, regulated through a controlled rectifier circuit, is tailored to align with the system's DC bus voltage, ensuring seamless integration into the hybrid energy system.



**Figure 4.4. Output Voltage of the PV without Grid Connection**

**Figure 4.4** figure illustrates the output voltage of the photovoltaic (PV) system connected to the DC bus. Through precise switching control, the PV output voltage is synchronized with the wind turbine output voltage, stabilizing the DC bus voltage at a consistent 387 V. This regulation ensures efficient energy management despite the variable power contributions from renewable sources.

- **PV System Voltage Regulation-** The PV system output voltage is influenced by solar irradiance and temperature. The converter's switching control dynamically adjusts the duty cycle to maintain the PV voltage within the DC bus requirement of 387 V. For instance, as irradiance increases and PV voltage rises, the duty cycle is reduced to prevent overshooting, as shown in Figure 4.4.
- **Wind Turbine Voltage Regulation with Controlled Rectification-** The wind turbine's AC output is converted to stable DC voltage using a controlled rectifier. Fluctuations in wind speed affect the turbine's AC



output, but the rectifier and its control circuits adjust to align the turbine's DC output with the DC bus voltage of 387 V. This regulation smoothes and synchronizes the turbine's contribution, as illustrated in Figure 4.3.

- **Voltage and Current on the AC Load-** Figures 4.4 and 4.6 depict the AC voltage and current waveforms across the load. The load voltage exhibits a square waveform with a peak-to-peak value of 400 V, while the load current is nearly sinusoidal with a peak-to-peak value of 20 A. The disparity arises due to the inductive characteristics of the load or circuit, which smooth the current.
- To achieve a fully sinusoidal current waveform, a filter unit, such as LC or LCL filters, can be installed at the load terminals. These filters reduce harmonic content, mitigate voltage ripple, and ensure smoother transitions in the voltage waveform, ultimately improving waveform quality.

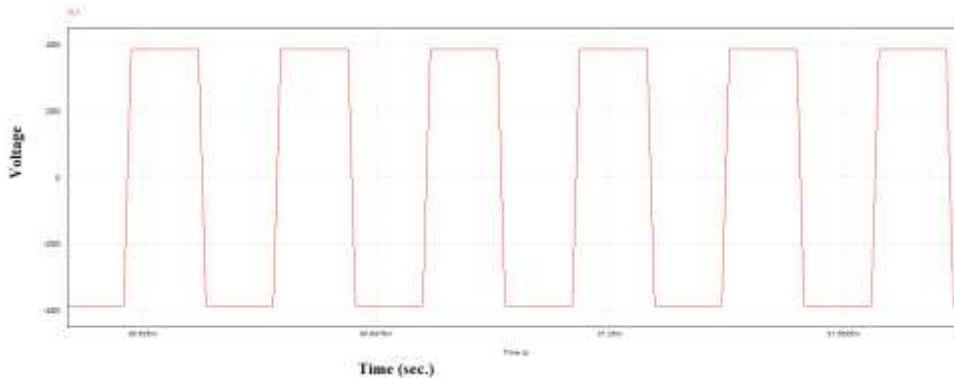


Figure 4.5. Waveform of AC voltage across the Load

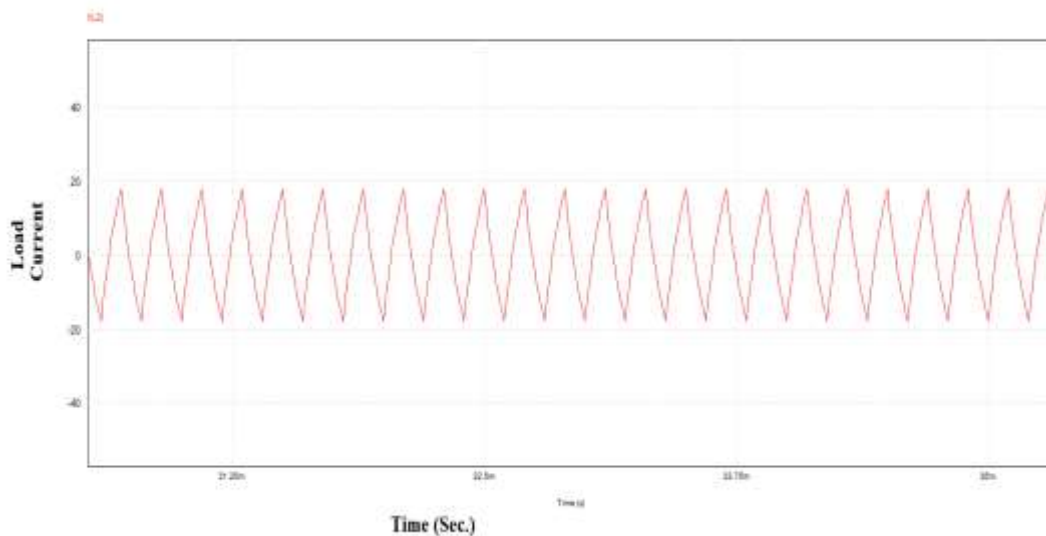


Figure 4.6. Wave form of the Current through the Load

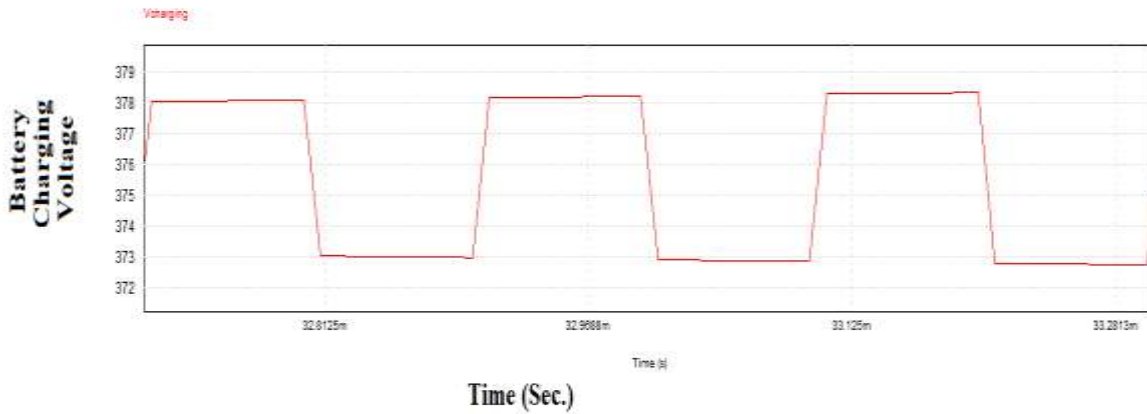
## 4.2. Results of Battery Charging Unit with Grid Connected

- **Battery Charging Voltage**

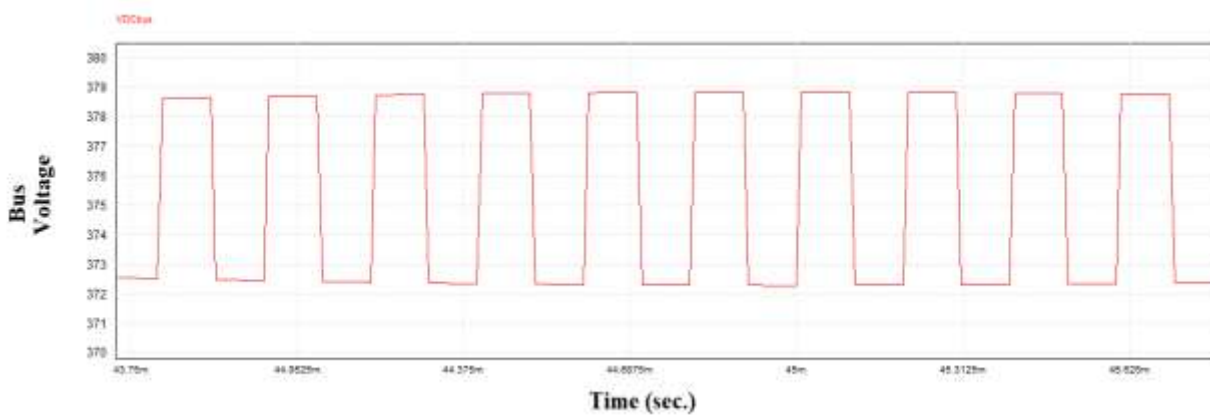
Figure 4.7 illustrate the battery charging voltage profile when the charging infrastructure is powered solely by the proposed hybrid energy system, with grid connection. Observing the simulation results, it is evident that the battery charging voltage does not experience any transient period. However, the nature of charging voltage near to DC there is very slight variation in the voltage level ie. From 372 to 379 V. although the charging



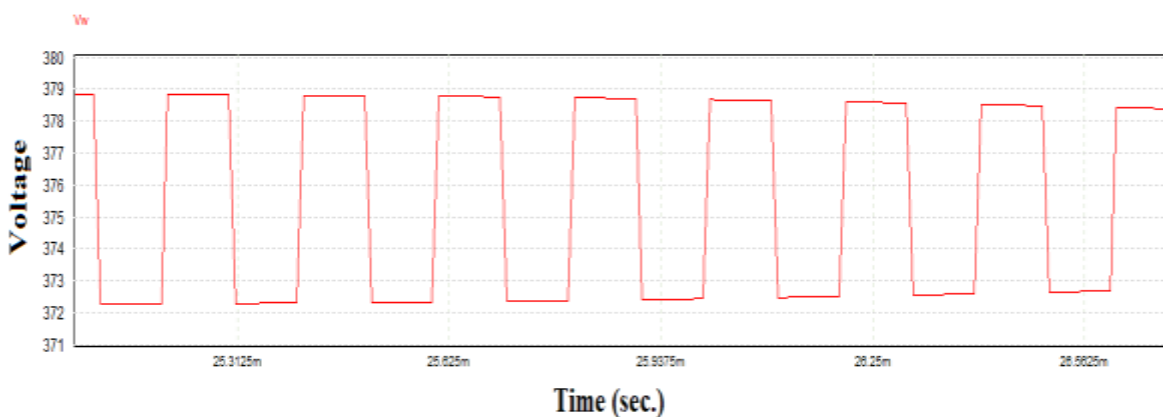
voltage goes slightly down as compare to without grid connect system. The voltage at DC bus and output of wind turbine is also maintained at the same voltage level as presented in figure 4.8.and figure 4.9. respectively.



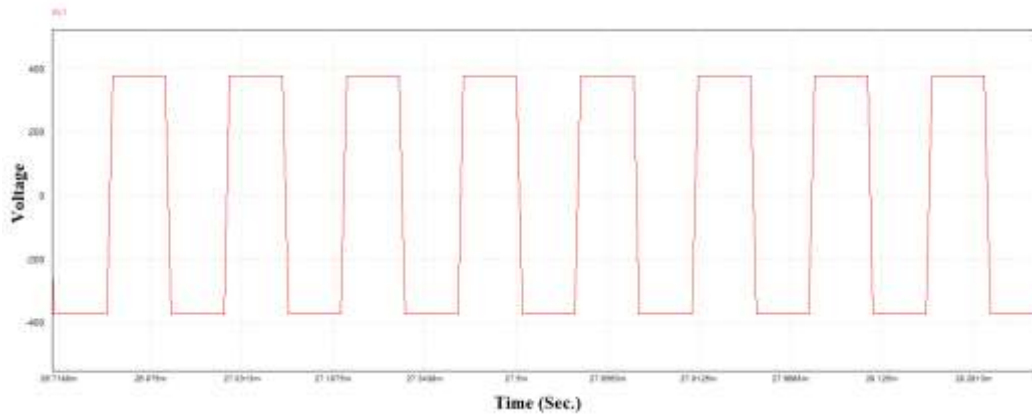
**Figure 4.7. Battery charging Voltage with grid connection**



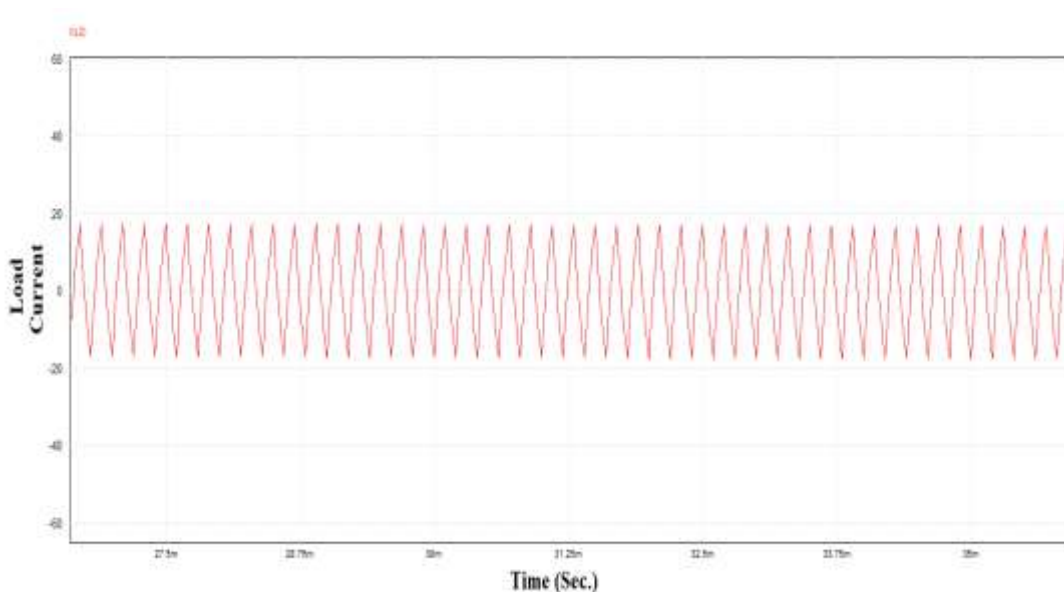
**Figure 4.8. Bus Voltage with grid connection**



**Figure 4.9. Output voltage from the wind turbine generator after converter**



**Figure 4.10. Load voltage across the AC load**



**Figure 4.11. Load Current through the AC load**

Figures 4.10 and 4.11 show that the AC voltage across the load has a peak-to-peak value of 400 V, while the peak-to-peak load current reaches 20 A. The waveform for the load voltage is clearly square, whereas the load current appears almost sinusoidal. This difference in waveform shapes suggests that while the load voltage is undergoing switching, the load current remains somewhat smoothed, likely due to the inductive properties of the load or the circuit.

## 5. Conclusion

The development and simulation of a hybrid energy storage system integrating photovoltaic (PV) and wind energy sources provides valuable insights into achieving reliable, efficient, and sustainable energy solutions for rural areas. Through the use of PSIM software, the system's performance was meticulously analyzed by examining key parameters, including the voltage stability of the PV and wind energy inputs, DC bus voltage regulation, battery charging dynamics, power quality, and harmonic distortion. This study revealed several key outcomes essential for the effective deployment of hybrid renewable systems in rural contexts.



## REFERENCES

1. Burla, S., Dash, R., Shukla, S. P., & Dwivedi, A. (2023, September). Improved Gravitational Search Algorithm based Hysteresis controller for Grid integrated SPV system. In 2023 IEEE 2nd International Conference on Industrial Electronics: Developments & Applications (ICIDeA) (pp. 620-624). IEEE.
2. Chattoraj, J., Dwivedi, A., & Pahariya, D. Y. (2017). Enhancement of power quality in SAPS system with multilevel inverter. *Int. J. Eng. Sci. Res. Technol.*, 6(5), 779-788.
3. Dwivedi, A. (2012). International Journal of Engineering Sciences & Management Benefits of Standalone Power Supply System. *Int. J. of Engg. Sci. & Mgmt.(IJESM)*, 2(1), 62-65.
4. Dwivedi, A., & Pahariya, Y. (2017). Design and Analysis of 1.4 MW Hybrid Saps System for Rural Electrification in Off-Grid Applications. *International Journal of Energy and Power Engineering*, 11(11), 1143-1147.
5. Dwivedi, A., & Pahariya, Y. (2018). Design of Continuous Mode Hybrid Standalone Power Station with Hybrid Controller to Select the Best Optimal Power Flow.
6. Dwivedi, A., & Pahariya, Y. (2021). Design and analysis of hybrid multilevel inverter for asymmetrical input voltages. *Journal of Electrical Engineering & Technology*, 16(6), 3025-3036.
7. Dwivedi, A., & Pahariya, Y. (2023). Techno-economic Feasibility Analysis of Optimized Stand-alone PV and Hybrid Energy Systems for Rural Electrification in INDIA. *Journal of The Institution of Engineers (India): Series B*, 104(4), 911-919.
8. Gautam SP, Kumar L, Gupta S (2015) Hybrid topology of symmetrical multilevel inverter using less number of devices. *IET Power Electron* 8(11):2125–213
9. Gupta KK, Ranjan A, Bhatnagar P, Kumar Sahu L, Jain S (2016) Multilevel inverter topologies with reduced device count: a review. *IEEE Trans Power Electron* 31(1):135–151.
10. Luo H, Dong Y, Li W, He X (2014) Module multilevel-clamped composited multilevel converter (M-MC2) with dual T-type modules and one diode module. *Journal of Power Electron* 14(6):1189–1196.
11. Pradeep Kumar VVS, Fernandes BG (2017) A fault tolerant single phase grid connected inverter topology with enhanced reliability for solar PV. *IEEE J Emerg SI Power Electron* 5(3):1254–1262.
12. Rajput, A.S., Dwivedi, A., Dwivedi, P., Rajput, D.S., Pattanaik, M. (2022). Read–Write Decoupled Single-Ended 9T SRAM Cell for Low Power Embedded Applications. In: Smys, S., Bestak, R., Palanisamy, R., Kotuliak, I. (eds) *Computer Networks and Inventive Communication Technologies . Lecture Notes on Data Engineering and Communications Technologies*, vol 75. Springer, Singapore.
13. Dwivedi, A., Moyal, V., Jhapte, R., Verma, S., Jain, A., Kumar, V., & Nigam, P. (2024). Intelligent Energy Storage System for Standalone PV Systems: Optimizing Battery Performance with Ultra capacitors. *Library Progress International*, 44(3), 13873-13882.
14. Dwivedi, A., Moyal, V., Jhapte, R., Verma, S., Chandrakar, M. K., Kumar, V., & Nigam, P. (2024). Design and Analysis of Modified AC to DC Converter Topology for Fast Electrical Vehicle Charging. *Library Progress International*, 44(3), 13883-13893.