



# Clean-Eco Friendly Vehicle: Charge Once Ride Twice (Two Wheeler)

Savitha M<sup>1</sup>, Yerriswamy W<sup>2</sup>, Umme Kulsum<sup>3</sup>, Usha Gowda K T<sup>4</sup>, Varsha D<sup>5</sup>, Veditha S<sup>6</sup>

<sup>1</sup> Professor, Department of Industrial and Production Engineering, SJCE, Mysuru, Karnataka.

<sup>2</sup> Associate Professor, Department of Industrial and Production Engineering, SJCE, JSSSTU, Mysuru, Karnataka

<sup>3,4,5,6</sup> Under Graduate, Department of Industrial and Production Engineering, SJCE, JSSSTU, Mysuru, Karnataka

Email: vedithakrish22@gmail.com

## How to Cite this Article:

W, Y., Kulsum, U., T, U. G. K., D, V. & S, V. (2026). Clean-Eco Friendly Vehicle: Charge Once Ride Twice (Two Wheeler). International Journal of Creative and Open Research in Engineering and Management, <i>02</i>(05). <https://doi.org/10.55041/ijcope.v2i5.381>

## License:

This article is published under the terms of the Creative Commons Attribution 4.0 International License (CC BY 4.0), which permits unrestricted use, distribution, and reproduction in any medium, provided the original author(s) and the source are credited.

© The Author(s). Published by International Journal of Creative and Open Research in Engineering and Management.



<https://doi.org/10.55041/ijcope.v2i5.381>

## ABSTRACT

The need of the frequent charging requirement of electric bikes by recovering and reusing wasted energy during motion and braking. An innovative approach to improving the efficiency and performance of electric two-wheelers through continuous energy recovery and intelligent energy management. The proposed system combines a wheel-mounted dynamo mechanism with a regenerative braking system to generate and recover electrical energy during both vehicle motion and deceleration. Unlike conventional electric vehicles that depend mainly on regenerative braking during braking conditions, the proposed model continuously produces auxiliary electrical energy while the wheels rotate. The generated energy is converted and regulated using a rectifier and DC-DC converter before being stored in an auxiliary storage unit such as a supercapacitor or lithium-ion battery. During acceleration, when power demand is highest, the stored energy is supplied to assist the motor through an Energy Management System, thereby reducing the load on the primary battery and improving overall energy efficiency. The integration of regenerative braking further enhances energy recovery by converting braking energy into reusable electrical power, minimizing energy loss during operation. The system is designed with lightweight mechanical components, optimized electrical circuitry, and smart control techniques to ensure efficient performance with minimal mechanical resistance. The proposed approach reduces charging

frequency, extends battery life, improves vehicle range, and supports environmentally sustainable transportation. Overall, the project demonstrates a practical, low-cost, and eco-friendly solution for next-generation urban electric mobility applications. Future improvements can include smart battery management, wireless charging, and AI-based energy optimization to increase efficiency and vehicle range.

**Keywords** - Eco-Friendly Transportation; Two-Wheeler EV; Energy Efficient Vehicle; Sustainable Mobility



## I. INTRODUCTION

Electric vehicles (EVs) are modern transportation systems that operate using electric power instead of conventional fossil fuel. EV bikes, also known as electric two-wheeler, use rechargeable batteries and electric motors to provide smooth, efficient, and eco-friendly transportation. Early electric bikes were simple battery-powered two-wheelers developed to provide an alternative to fuel-based transportation. The concept of electric bicycles and bikes began in the late 19th century. The early EV bikes used heavy lead-acid batteries and low-power motors, which limited their speed, range, and efficiency, EV bikes were mainly used for short-distance travel. These early developments laid the foundation for modern electric bikes. Improvements in lithium-ion batteries, motor efficiency, and electronic control systems helped transform EV bikes into reliable, energy-efficient, and eco-friendly vehicles used worldwide. The implementation of regenerative braking system in EV bikes, is an energy recovery mechanism that converts the vehicle's kinetic energy into electrical energy during braking. Our innovation is charging the bike during acceleration mode. Electric vehicles (EV bikes) using the dynamo principle are developed to improve energy efficiency by converting mechanical energy into electrical energy while the vehicle is in motion. The dynamo principle works on the concept of electromagnetic induction, where mechanical energy is converted into electrical energy. In EV bikes, the rotating wheel or motor shaft can drive a dynamo or generator, which produces electricity to support the battery system or power electrical components.

## II. LITERATURE REVIEW

An optimized charging method for lithium-ion batteries using a soft actor-critic (SAC) reinforcement learning algorithm is proposed. The study employs the Single Particle Model with electrolyte and thermal dynamics to represent battery aging and charging behavior more accurately. Although the model provides detailed analysis compared to the basic Single Particle Model (SPM), it involves a highly complex mathematical structure consisting of partial differential equations (PDEs), ordinary differential equations, and algebraic equations. Due to this complexity, the implementation of model-based algorithms becomes computationally demanding, making them difficult to apply in practical Battery Management Systems (BMSs). The increasing concerns over carbon dioxide emissions, greenhouse effects, and the depletion of fossil fuels have accelerated the demand for eco-friendly and sustainable alternatives to internal combustion engine (ICE) vehicles. As a result, electric vehicles (EVs) have gained widespread adoption in recent years due to their low emissions and reduced dependence on petroleum fuels. It was estimated that the number of EVs worldwide would exceed 35 million by 2022. Despite these advantages, the rapid growth of EVs creates significant challenges for power distribution systems, including power quality issues, increased stress on transmission lines and distribution transformers, higher harmonic distortion, and elevated fault currents in the electrical grid. Wireless power transfer (WPT) technologies for electric vehicles are widely researched due to their ability to provide convenient and cable-free charging solutions. These technologies are mainly classified into near-field, medium-field, and far-field charging methods. Near-field charging includes inductive charging, magnetic resonance charging, and capacitive coupling, which are commonly used because of their higher efficiency and safety. Medium-field charging mainly uses magnetic-gear charging techniques, while far-field charging includes advanced methods such as laser, microwave, and radio-wave power transfer. In all wireless charging systems, the charging process can occur either when the vehicle is stationary or in motion, and the system mainly consists of two important sections: the ground assembly (GA), which transmits power, and the vehicle assembly (VA), which receives and converts the transmitted energy for battery charging.

## III. RESEARCH GAP

Existing regenerative braking systems mainly recover energy during deceleration and braking by converting kinetic energy into electrical energy. During acceleration, the motor consumes high power, making simultaneous charging difficult, and current EV bikes lack efficient systems to recover or generate energy in this mode. Additionally, integrated energy management systems, hybrid motor-generator concepts, flywheel-based charging, and auxiliary charging mechanisms are still underdeveloped for two-wheelers. Therefore, there is a need for advanced dual-mode



energy recovery systems that can improve battery charging during both braking and acceleration without reducing vehicle performance or efficiency. Although regenerative braking technology is widely used in electric vehicles to recover energy during braking, its application is limited to deceleration conditions only. Current research mostly focuses on improving braking efficiency, battery recovery rate, and motor control, while charging during acceleration mode remains largely unexplored in EV bikes. This highlights the need for innovative

energy harvesting and charging techniques that can support battery charging during acceleration or vehicle motion, thereby increasing driving range, improving energy efficiency, and reducing dependency on external charging.

#### IV. PROBLEM STATEMENT

Electric vehicles rely primarily on battery energy, which limits their travel range. During acceleration, EVs consume the highest amount of power, causing the battery level to drop quickly. Existing systems recover energy only during braking, which is insufficient during short-distance urban rides where braking is minimal. How can we generate, store, and reuse secondary energy \*during motion\* (not only during braking) to reduce primary battery consumption? The current generation of electric bikes relies primarily on **manual plug-in charging systems**, which introduce several engineering limitations, including unreliable user-dependent connections, inconsistent charging currents, and potential mechanical and electrical failures due to improper handling of charging ports. Manual connectors are prone to wear, misalignment, arcing, and environmental exposure (dust, moisture, vibration), leading to reduced system efficiency and shortened component life cycles. Additionally, the absence of an automated interface restricts seamless charging integration in smart mobility ecosystems.

#### V. OBJECTIVES

The objectives of this study are as follows:

1. Implement systems or technologies that allow a single charge to support multiple trips (“once ride twice”), reducing overall energy consumption per journey.
2. Lower the carbon footprint of daily commuting by shifting users to low-emission or zero-emission transportation options.
3. Help users save money through efficient use of electric transport, longer battery life, shared usage models, or low-cost charging options.
4. Promote research and development of new charging technologies, smart battery systems, or mobility-sharing platforms.

#### VI. METHODOLOGY

The project includes design, development, and testing of the vehicle to check the charging of the vehicle during acceleration mode. First the idea generation and design of 2D and 3D models. And incorporating this design on to real bike using the components. EV Bike, HI-Power Battery, Permanent-Magnet Direct Current Motor, Vehicle Speed Controller, DC-DC Converter, Lithium-Ion Battery. Using the dynamo principle to improve energy efficiency by converting mechanical energy into electrical energy while the vehicle is in motion. A dynamo works based on electromagnetic induction, where electricity is generated when a conductor moves through a magnetic field. In EV bikes, the rotation of the wheels or motor shaft is connected to a small generator or dynamo. As the wheel rotates, the dynamo also rotates and produces electrical energy. This generated electricity can be used to support the battery, operate lights and displays, or assist auxiliary electrical systems. The concept is mainly aimed at reducing energy wastage and improving the overall performance of the electric vehicle.

## VII. 2D AD 3D DIAGRAMS

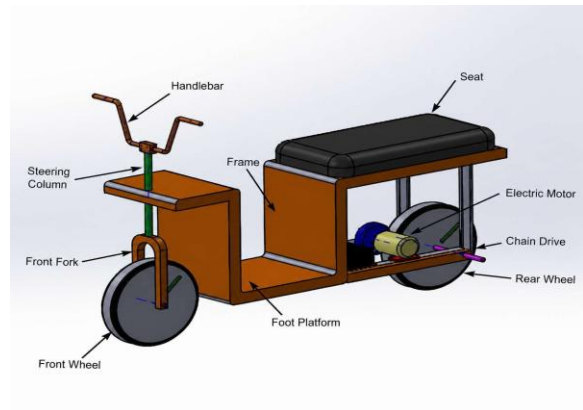
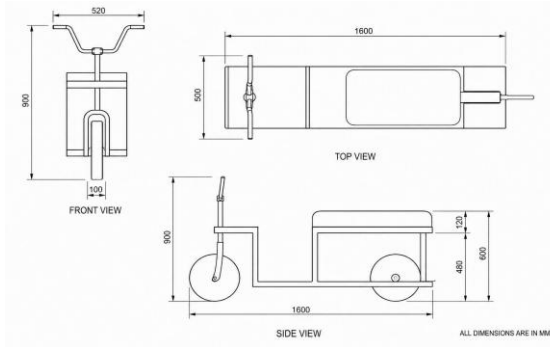

## VIII. 3D MODELS

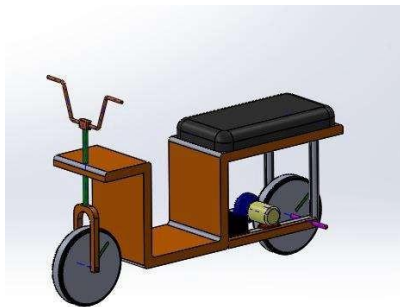

### ISOMETRIC VIEW

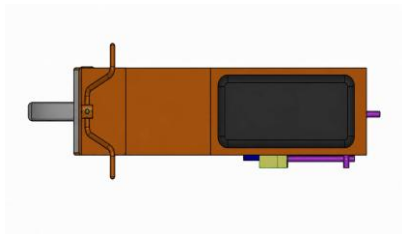

### TOP VIEW

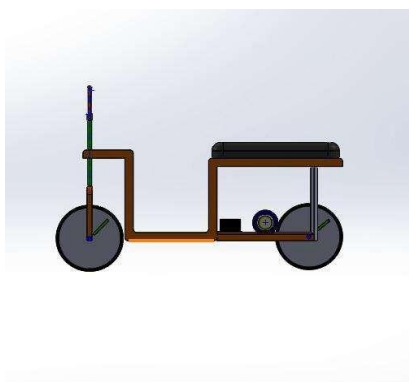

### SIDE VIEW

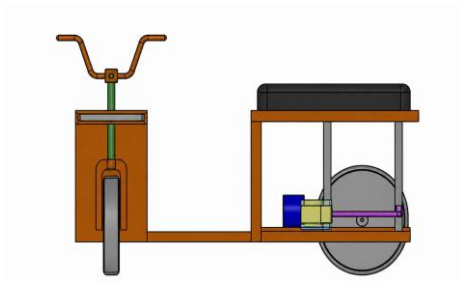

## FRONT VIEW

## RESULTS AND DISCUSSIONS

The results of the project, known by the calculations. The charging and energy management system during acceleration mode in an EV bike provides efficient power delivery and smooth vehicle performance. During acceleration, the battery supplies electrical energy to the motor, enabling the bike to achieve higher speed with instant torque. The motor controller successfully regulates the current and voltage according to the throttle input, ensuring stable acceleration and better riding comfort. The use of lithium-ion batteries and advanced control systems improves the overall efficiency of the electric vehicle.

The analysis of charging support systems during acceleration shows that auxiliary energy recovery methods such as regenerative support, flywheel energy storage, or dynamo-assisted charging can help reduce the load on the main battery. Although the generated charging energy during acceleration is limited, these systems contribute to better energy utilization and improved battery performance. The Battery Management System (BMS) also plays an important role by protecting the battery from overheating, overcharging, and excessive current flow during high-power operation.

Table I: System Component Improvement

Regenerative Braking	4–6%
BMS Optimization	2–3%
Motor Controller (FOC)	2–3%
Mechanical Improvements	1–2%
Total	~10%

## IX. CONCLUSION

The Clean Eco-Charge system demonstrates an innovative approach to sustainable transportation by harnessing the dynamo principle to recover and store energy during vehicle operation. By converting kinetic energy into electrical energy, this system allows the vehicle to effectively “ride twice” from a single energy input—first by normal propulsion and then by reusing the stored energy during acceleration. The acceleration mode showcases how regenerative energy can supplement power demands, reducing fuel or battery consumption, lowering emissions, and enhancing overall energy efficiency. This approach not only promotes eco-friendly mobility but also highlights the potential of integrating energy recovery systems in modern vehicles. In conclusion, the project illustrates that simple mechanical and electrical principles, when applied thoughtfully, can contribute significantly to sustainable transportation solutions, making each ride more efficient and environmentally responsible.



## ACKNOWLEDGMENT

We sincerely thank the Vice Chancellor, Registrar, and Principal of JSS Science and Technology University, Mysuru, for giving us the opportunity to carry out this project. We are especially grateful to our guides, Dr. Savitha M and Dr. Yerriswamy W, Associate Professors in the Department of Industrial and Production Engineering, for their invaluable guidance and support throughout the project. We also extend our thanks to the faculty and staff of the department for their assistance. Lastly, we appreciate all those who directly or indirectly contributed to the successful completion of this major project.

## REFERENCES

- [1]. Kim M, Baek J, Han S (2020) Optimal charging method for effective Li-ion battery life extension based on reinforcement learning. arXiv e-prints.
- [2]. Rizvi SAA, Xin A, Masood A, Iqbal S, Ullah Jan M, Rehman H (2018) Electric vehicles and their impacts on integration into power grid: a review. In: Presented at the 2nd IEEE Conference on Energy Internet and Energy System Integration (EI2), Bei Jing, China, Oct. 20–22, 2018.
- [3]. SAEJ2954: Wireless Power Transfer for Light-Duty Plug-in/Electric Vehicles and Alignment Methodology; Surface Vehicle Information Report; SAE International: Warrendale, PA, USA, 2019.