



IoT - Based Wireless Smart Energy Meter along with theft Alerting System

Mr. THANGARAJ R, M.E.,

Assistant Professor

Department of EEE.,

Coimbatore Institute of Engineering and Technology, Coimbatore.

Thangarajr67@gmail.com

Ragul L,

Student,

Department of Electrical and Electronics Engineering,

Coimbatore Institute of Engineering and Technology,

Coimbatore, India.

ragullakshmanan2424@gmail.com

Mathivanan P,

Student,

Department of Electrical and Electronics Engineering,

Coimbatore Institute of Engineering and Technology,

Coimbatore, India.

mathi777vanan@gmail.com

Amirtha Sri S,

Student,

Department of Electrical and Electronics Engineering,

Coimbatore Institute of Engineering and Technology,

Coimbatore, India.

amirthasri2127@gmail.com

Nandha Kumar R,

Student,

Department of Electrical and Electronics Engineering,

Coimbatore Institute of Engineering and Technology,

Coimbatore, India.

nandhakumar786708@gmail.com

Abstract - The rapid advancement of Internet of Things (IoT) technologies has enabled the development of intelligent energy management systems for efficient monitoring and control of electricity consumption. This paper presents the design and implementation of an IoT-based smart energy meter using the ESP32 microcontroller integrated with voltage and current sensing modules for real-time power measurement. The system enables continuous data acquisition and transmits consumption data to a cloud-based platform such as Blynk, allowing users to monitor energy usage remotely through mobile or web interfaces. A key feature of the proposed system is Threshold-Based Cost Management, which detects when energy consumption exceeds predefined limits (e.g., 100 units) and provides timely alerts to users. This proactive notification system helps consumers regulate their electricity usage and avoid excessive billing. The proposed solution offers a cost-effective, scalable, and user-friendly approach to modern energy monitoring, contributing to energy conservation and smarter grid utilization.

Keyword - IoT, Smart Energy Meter, ESP32, GSM Communication, Wireless Monitoring, Energy Consumption, Cloud Platform, Real-Time Monitoring, Threshold Alert, Theft Detection Control .

I. INTRODUCTION

Efficient energy monitoring has become essential due to increasing electricity demand and the need for better resource management. Traditional energy meters only record total consumption and require manual reading, which is time-consuming and prone to errors. They also lack real-time monitoring and do not provide insights into usage patterns. Moreover, conventional systems are unable to detect electricity theft or abnormal consumption effectively.

The advancement of Internet of Things (IoT) technology, smart energy monitoring systems enable real-time data acquisition and remote access. These systems use sensors and microcontrollers to measure electrical parameters accurately and transmit data wirelessly to cloud platforms. In addition to IoT

communication, GSM technology is used to send instant alerts and notifications to users through SMS.

Users can monitor their energy usage through mobile or web applications from any location. Threshold-based alerts help control excessive consumption and reduce electricity bills. The inclusion of GSM-based messaging ensures reliable communication even in the absence of internet connectivity. Theft detection mechanisms further enhance system security by identifying unauthorized usage and generating immediate alerts. Thus, the system provides an efficient, reliable, and user-friendly solution for modern energy management.

II. ABBREVIATIONS AND ACRONYMS

- **IoT** – Internet of Things
- **ESP32** – Espressif 32-Bit Microcontroller
- **HC-05** – Bluetooth Serial Communication Module
- **GSM** – Global System for Mobile Communication
- **SIM800L** – GSM/GPRS Communication Module
- **MCU** – Microcontroller Unit
- **AC** – Alternating Current
- **DC** – Direct Current

III. LITERATURE REVIEW

1 IOT-Based Prepaid Energy Meter with Theft Monitoring and Control System

Ahmed Fraz *et al.* proposed an IoT-based prepaid energy



meter with theft monitoring and control system that integrates real-time energy measurement with automated billing. The system uses a microcontroller to monitor consumption and update prepaid balance dynamically. A relay mechanism is employed to disconnect the load when the balance is exhausted. Theft detection is achieved through current mismatch and tamper sensing techniques. GSM communication is used to

send alert notifications during abnormal conditions. The study shows improved billing efficiency, reduced energy theft, and enhanced transparency compared to conventional metering systems.

2 IoT-Powered Advanced Energy Meter Monitoring and Tamper Prevention System Using Logical Sensor

Ramya T *et al.* proposed an IoT-powered advanced energy meter monitoring and tamper prevention system using logical sensors. The system integrates a high-precision energy metering module with a microcontroller for real-time data acquisition and processing. It employs rule-based and machine learning-assisted techniques to detect tampering conditions such as neutral bypass, reverse polarity, and magnetic interference. Secure communication is achieved using IoT protocols for reliable data transmission to cloud platforms. The system provides continuous monitoring and instant alert generation during abnormal conditions. The study demonstrates improved accuracy, enhanced security, and effective prevention of energy theft in modern smart metering systems.

IV METHODOLOGY

A. System Overview

The proposed system is an IoT-based wireless smart energy meter designed for efficient monitoring and control of electrical energy consumption. The power supply unit converts AC input into regulated DC using a bridge rectifier, filter capacitor, and buck converter, ensuring stable operation of all components. Voltage and current are measured using a Voltage Transformer (VT) and Current Transformer (CT), which safely step down electrical values for processing.

The sensed signals are fed into the ESP32 microcontroller, which acts as the central processing unit. It processes the data and calculates key electrical parameters such as voltage, current, power, and energy consumption. The calculated values are displayed on an LCD for local monitoring. Additionally, the system uses Wi-Fi connectivity to transmit real-time data to the Blynk IoT platform, enabling users to monitor energy usage remotely through a mobile application.

A GSM module is integrated to provide SMS alerts during abnormal conditions such as overload, excessive usage, or suspected electricity theft. Relay modules are used to control electrical loads remotely based on user commands or system conditions. Overall, the system offers a smart, reliable, and secure solution for modern energy management with enhanced monitoring, control, and safety features.

B. Working Principle

The proposed system operates by measuring electrical parameters and enabling real-time monitoring and control. The AC supply is first converted into DC using a bridge rectifier, and a filter capacitor is used to smooth the output. A voltage regulator provides a stable DC supply, and a buck converter further steps down the voltage to required levels (5V/3.3V) for the ESP32 and other components. A Voltage Transformer (VT) and Current Transformer (CT) are used to measure voltage and current safely, and their outputs are given to the ESP32 through ADC pins. The ESP32 processes these signals and calculates voltage, current, power, and energy consumption. The calculated values are displayed on an LCD

for local monitoring. The system transmits real-time data to the Blynk IoT platform via Wi-Fi, allowing users to monitor energy usage remotely. A GSM module sends SMS alerts during overload or abnormal conditions. Relay modules are used to control the load by switching appliances ON/OFF for protection and remote operation, making the system efficient, reliable, and secure.

C. Block Diagram

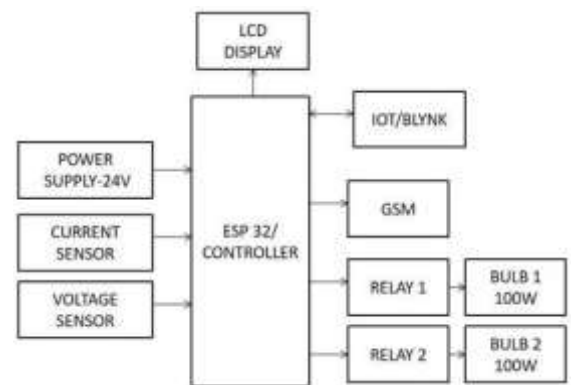

Fig 1: Block Diagram of IoT-Based Smart Energy Meter

D. Mathematical Modeling

The proposed IoT-based smart energy meter is mathematically modeled to estimate electrical parameters such as voltage, current, power, and energy consumption in real time. The system acquires analog signals from voltage and current sensors, which are then converted into digital values using the Analog-to-Digital Converter (ADC) of the ESP32 microcontroller. These digital values are calibrated using appropriate scaling factors to obtain accurate electrical measurements. This modeling approach ensures precise computation and continuous monitoring of energy usage.

The RMS voltage is calculated from the sensor output using a calibration constant as:

$$V = V_{measured} \times K_v \quad (1)$$

where $V_{measured}$ is the sensed voltage and K_v is the voltage scaling factor.



Similarly, the load current is determined using the relation:

$$I = \frac{V_{\text{sensor}}}{R_{\text{burden}}} \quad (2)$$

where V_{sensor} is the sensor output voltage and R_{burden} is the burden resistance used in the current sensing circuit.

The instantaneous power consumed by the load is given by:

$$P = V \times I \times \cos \phi \quad (3)$$

where $\cos \phi$ represents the power factor of the load. For purely resistive loads such as bulbs, the power

factor is approximately equal to unity, simplify in the calculation.

The total energy consumption is obtained by integrating power over time. In digital implementation, this is achieved using discrete sampling as:

$$E = \sum P \cdot \Delta m \quad (4)$$

where Δt is the sampling interval. For simplified analysis over a fixed duration, energy can also be expressed as:

$$E = P \times t \quad (5)$$

Energy is expressed in kilowatt-hours (kWh), which is the standard unit used for billing purposes:

$$1 \text{ kWh} = 1000 \text{ W} \times 1 \text{ hour}$$

To improve system functionality, a threshold-based monitoring condition is implemented:

$$E \geq E_{\text{limit}} \Rightarrow \text{Alert Triggered} \quad (6)$$

This ensures that users are notified when energy consumption exceeds a predefined limit.

Furthermore, the system incorporates a basic theft detection mechanism by analyzing abnormal current variations:

$$I_{\text{measured}} > I_{\text{expected}} \Rightarrow \text{Theft Detected}$$

The calculated parameters are continuously processed by the ESP32 and transmitted to the IoT platform via Wi-Fi for real-time visualization. In addition, the GSM module sends instant alerts during abnormal conditions. This comprehensive mathematical model ensures accurate estimation, efficient monitoring, and reliable operation of the smart energy meter system, making it suitable for modern energy management applications.

Voltage (V)	Current (A)	Power (W)	Time (hrs)	Energy (Wh)
230	0.5	115	1	115
230	1	230	2	460
230	1.5	345	1	345
230	2	460	0.5	230

Table 1: TABLE I. POWER AND ENERGY CALCULATION

V. HARDWARE DESCRIPTION

The proposed system consists of an ESP32 microcontroller as the main processing unit, which handles data acquisition, processing, and communication. Voltage and current sensors are used to measure electrical parameters from the AC supply, where the voltage sensor provides a scaled analog signal and the current sensor converts load current into a proportional voltage signal. A regulated power supply unit converts 230V AC into stable DC voltages required for system operation. The ESP32 processes the sensor data to calculate power and energy consumption. A 16x2 LCD display is used for local monitoring of real-time values. The built-in Wi-Fi of the ESP32 enables communication with the IoT platform (Blynk) for remote monitoring. A GSM module is integrated to send SMS alerts during overload or abnormal conditions. Additionally, a relay module is used to control electrical loads remotely, ensuring efficient and reliable system operation.

VI. SOFTWARE DESCRIPTION

The software implementation of Blynk in the IoT-based smart energy meter involves connecting the ESP32 microcontroller to the Blynk cloud using an authentication token and Wi-Fi module. The sensor data such as voltage, current, power, and energy consumption is continuously transmitted to the Blynk server for real-time monitoring. A user-friendly mobile dashboard is created using widgets like gauges, graphs, and displays to visualize the electrical parameters effectively. The system also integrates alert mechanisms to notify users instantly in case of power theft or abnormal consumption. Blynk software enables efficient remote monitoring, control, and data visualization for smart energy management applications.

VII. RESULTS

The proposed IoT-based smart energy meter was successfully developed and tested. The system accurately measured voltage, current, and energy consumption in real time. The measured data was displayed on the LCD and transmitted to the cloud platform for remote monitoring. The system effectively detected abnormal conditions such as overload and tampering, and alert messages were sent through the GSM module. The relay module successfully controlled the load by disconnecting power during fault conditions. The overall performance of the system was found to be reliable and efficient.



a. Blynk Output of Smart Energy Meter



Fig 2 : Blynk Output of Smart Energy Meter

VIII CONCLUSION

The proposed system provides an efficient and reliable solution for real-time energy monitoring and management by integrating sensors with the ESP32 microcontroller. It accurately measures voltage, current, power, and energy consumption while enabling remote monitoring through an IoT cloud platform. The system allows users to track their electricity usage via mobile applications, improving awareness and control. The implementation of a threshold-based alert mechanism helps in reducing excessive energy consumption, while GSM communication ensures instant SMS alerts during critical conditions even without internet connectivity. Additionally, the inclusion of a theft detection feature enhances system security by identifying abnormal usage patterns. Remote control of electrical loads further improves convenience and efficiency. Overall, the system is cost-effective, scalable, and user-friendly, contributing to energy conservation and the development of smart power systems.

REFERENCES

- [1] R. Patil et al., "Smart Energy Meter," IJERT, 2020.
- [2] .Singh et al., "IoT-Based Energy Meter," IRJET, 2021.
- [3] B. Singh and R. Kumar, "Smart Meter with Theft Detection," IJERT, 2021.
- [4] Kumar and B. Singh, "Design of IoT-Based Smart Energy Meter with Theft Detection," International Journal of Engineering Research & Technology (IJERT), 2021.
- [5] S. Patel et al., "Wireless Smart Energy Meter Using

ESP32," International Journal of Innovative Technology and Exploring Engineering (IJITEE), 2022.

- [6] M. Sharma and R. Gupta, "IoT-Based Energy Monitoring System with GSM Alert," International Journal of Scientific Research in Engineering and Management (IJSREM), 2022.
- [7] Garrab.A, Bouallegue.A, Ben Abdullah, A new AMR approach for energy savings in Smart Grids using Smart meter and partial power line communication", IEEE First International Conference on ICICS,vol 3, pp. March 2012.
- [8] Landi,c.: Dipt. Di Ing.dell"Inf, SecondaUniv di Napoli,Aversa,Italy; Merola p."ARM-based energy management system using smart meter and Web server",IEEE instrumentation and measurement technology conference binjing, pp.1-5 may 2011.
- [9] B. S. Koay, S. S. Cheah, Y. H. Sng, P. H. Chong, P. Shum, Y. C. Tong, X. Y. Wang, Y. X. Zuo and H. W. Kuek, "Design and implementation of Bluetooth energy meter", IEEE Proceedings of the 4th International Joint Conference of the ICICS, vol. 3, pp. 1474-1477, Dec,2003.
- [10]N. Fathima, A. Ahammed, R. Banu, B.D. Parameshachari, and N.M. Naik, "Optimized neighbor discovery in Internet of Things (IoT)," In Proc. of International Conference on Electrical, Electronics, Communication, Computer, and Optimization Techniques (ICEECCOT), pp. 1-5, 201
- [11]Mohammad Hossein Yaghmaee Design and Implementation of an Internet of Things Based Smart Energy Metering" 6th IEEE International Conference on Smart Energy Grid Engineering 2018.
- [12] Himanshu kpatel "arduino based smart energy meter" 2nd Int'l Conf. on Electrical Engineering and Information &Communication Technology (ICEEICT) 2018.
- [13] "Bibek Kanti Barman, et.al" proposed paper "smart meter using IoT" department of international electronics and electrical engineering (IEEE) 2017.