



Smart Spraying Rover

Mayuri Nawale¹, Rutuja Shelke², Ritu kadam³,
Under the Guidance of Ms.Sapna Jadhav⁴

¹ Electronics & Telecommunication, Shatabdi Institute of Engineering, Nashik, Maharashtra, India

² Electronics & Telecommunication, Shatabdi Institute of Engineering, Nashik, Maharashtra, India

³ Electronics & Telecommunication, Shatabdi Institute of Engineering, Nashik, Maharashtra, India

⁴Project Guide, Department of Engineering, Shatabdi Institute of Engineering & Research, Nashik, Maharashtra, India

Corresponding Author Email: mayurinawale629@gmail.com

How to Cite this Article:

Nawale, M., Shelke, R. & kadam, R. (2026). Smart Spraying Rover. International Journal of Creative and Open Research in Engineering and Management, <i>02</i><i>(05)</i>. <https://doi.org/10.55041/ijcope.v2i5.811>

License:

This article is published under the terms of the Creative Commons Attribution 4.0 International License (CC BY 4.0), which permits unrestricted use, distribution, and reproduction in any medium, provided the original author(s) and the source are credited.

© The Author(s). Published by International Journal of Creative and Open Research in Engineering and Management.



<https://doi.org/10.55041/ijcope.v2i5.811>

Abstract—

The Smart Spraying Rover is an intelligent and automated rover system designed for smart agricultural monitoring and object detection applications. The main objective of this project is to develop a compact and efficient rover capable of performing automated movement, RFID-based identification, and AI-powered image processing for real-time monitoring. The system integrates modern technologies such as ESP32-CAM, NodeMCU, RFID sensors, and Edge Impulse to enhance automation and intelligent decision-making.

The rover is designed to move automatically and detect specific objects or conditions using integrated sensors and a camera module. The ESP32-CAM captures real-time images, while the Edge Impulse platform is used to process and classify data using TinyML-based artificial intelligence techniques. RFID technology is incorporated for object recognition and authentication purposes, improving system security and operational efficiency. The system also supports wireless communication and automated control for better performance in agricultural and monitoring environments.

Experimental testing demonstrated effective rover movement, reliable RFID detection, and successful AI-based monitoring performance. The developed Smart Spring Rover provides a low-cost, compact, and efficient solution for smart automation and agricultural applications. Furthermore, the project serves as a practical implementation of IoT, embedded systems, and artificial intelligence technologies for future smart farming systems.

Keywords— Smart Spring Rover, ESP32-CAM, NodeMCU ESP8266, RFID Sensor, Edge Impulse, Smart Agriculture, IoT, Automation, Real-Time Monitoring.



I. INTRODUCTION

The Smart Spraying Rover is an intelligent and automated rover system designed to improve monitoring, object detection, and smart agricultural applications through embedded systems and artificial intelligence technologies. In recent years, automation and smart monitoring systems have become highly important in agriculture and industrial environments to reduce manual effort and improve operational efficiency. Traditional monitoring methods often require continuous human supervision, which may increase labor cost and reduce efficiency.

The Smart Spring Rover is developed as a compact and intelligent solution capable of performing automated movement, RFID-based identification, and AI-based object monitoring. The system integrates modern hardware components such as ESP32-CAM, NodeMCU, RFID sensors, motors, and relay modules to achieve efficient system automation. The ESP32-CAM module captures real-time images for monitoring purposes, while Edge Impulse technology enables artificial intelligence-based classification using TinyML techniques.

RFID technology is incorporated into the system to identify authorized objects or access conditions, ensuring security and reliable system control. The rover is capable of moving automatically and performing monitoring tasks based on predefined instructions and sensor feedback. The use of wireless communication and intelligent automation improves the flexibility and efficiency of the overall system.

II. LITERATURE REVIEW

Smart rover systems and automation technologies have gained significant attention in modern agricultural and monitoring applications. Several researchers have developed automated rover systems to improve surveillance, crop monitoring, and environmental analysis. Traditional rover systems mainly focused on manual control and lacked intelligent decision-making capabilities.

Recent advancements in artificial intelligence and embedded systems have enabled the development of smart monitoring systems capable of real-time analysis and automation.

Research studies show that ESP32-CAM modules provide efficient image capturing and wireless communication for remote monitoring applications. These systems are widely used in surveillance, agriculture, and automation due to their compact size and cost-effectiveness.

Studies on RFID technology indicate that RFID-based systems improve identification accuracy and provide secure authentication in automated systems. RFID sensors are commonly used for object recognition, smart access control, and inventory management because of their reliability and fast response.

Artificial intelligence platforms such as Edge Impulse have significantly improved intelligent embedded systems by enabling TinyML-based machine learning models on low-power microcontrollers. Edge Impulse supports real-time image classification and data processing, making it highly suitable for smart agricultural and rover-based applications.



Figure 1 Smart Spraying Rover

Several existing systems use robotic rovers for environmental monitoring; however, many systems suffer from limitations such as high implementation cost, low portability, and lack of intelligent automation. Therefore, the Smart Spring Rover is developed to overcome these limitations by integrating automation, RFID authentication, image processing, and AI-based decision-making into a single compact system.



SYSTEM DEVELOPMENT

1. System Architecture

The Smart Spraying Rover consists of multiple integrated hardware and software components designed to perform automated monitoring and intelligent movement. The system architecture includes ESP32-CAM, NodeMCU, RFID sensor, relay module, motor driver, camera system, and Edge Impulse platform. The ESP32-CAM captures images, while the RFID sensor provides authentication and object detection. The NodeMCU acts as the central controller for processing sensor data and controlling rover movement.

Working Principle

The Smart Spraying Rover operates based on automation and intelligent monitoring principles. Initially, the rover starts moving according to programmed instructions. The RFID sensor continuously scans for authorized tags or objects. Once an RFID tag is detected, the ESP32-CAM captures an image and sends it for processing. Edge Impulse analyzes the captured data and performs classification using TinyML models. Based on the output, the system performs necessary actions and controls rover operation.

2. Circuit Design

The circuit design of the Smart Spraying Rover integrates ESP32-CAM, NodeMCU ESP8266, RFID sensor (MFRC522), motor driver, relay module, and DC motors for automated monitoring and movement. The NodeMCU acts as the main controller and processes sensor data to control rover movement. The RFID sensor detects authorized tags, while the ESP32-CAM captures real-time images for AI-based monitoring using Edge Impulse. A motor driver controls the rover's movement, and the relay module performs automated operations. The system is powered using a battery supply for smooth and stable performance.

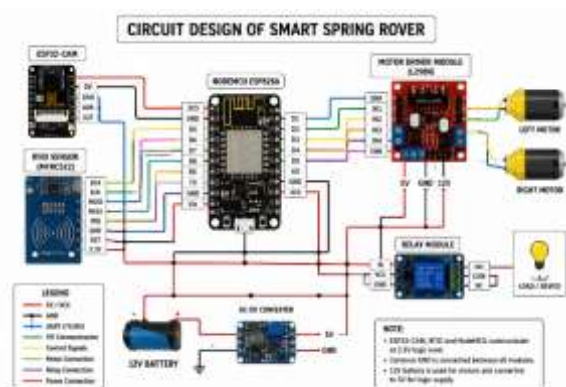

Figure 2. Circuit Diagram of Smart Spraying Rover

3. Components Used

The major hardware components used in the Smart Spring Rover include ESP32-CAM, NodeMCU ESP8266, RFID sensor (MFRC522), relay module, motor driver, DC motors, battery supply, jumper wires, and wheels. Software tools include Arduino IDE, Edge Impulse platform, and embedded programming languages such as C++.

4. ESP 32-CAM Module

The ESP32-CAM module is a low-cost microcontroller with an inbuilt camera used for real-time image capturing and monitoring in the Smart Spraying Rover. It supports Wi-Fi and Bluetooth communication, enabling wireless image transmission and remote monitoring. The module captures images during rover movement and processes them for AI-based classification using the Edge Impulse platform. Due to its compact size and low power consumption, ESP32-CAM is highly suitable for embedded and IoT applications..

5. Node MCU ESP8266

The NodeMCU ESP8266 acts as the main controller of the Smart Spraying Rover. It processes input data from sensors and controls the movement of the rover. The NodeMCU supports Wi-Fi connectivity and allows communication between hardware components. It controls the motor driver, RFID system, and other connected devices according to programmed instructions. The module is programmed using the Arduino IDE and supports embedded C/C++ programming.



6. MFRC522 RFID Reader

The MFRC522 RFID Reader is used for RFID-based authentication and object detection. It reads RFID tags or cards through radio frequency communication and sends the information to the NodeMCU controller. The sensor helps improve system security by allowing only authorized access or predefined actions. The MFRC522 module operates at 13.56 MHz frequency and communicates using the SPI protocol.

7. Relay Module

The relay module is an electrically operated switching device used to control external electrical components in the Smart Spring Rover. It allows low-voltage signals from the NodeMCU to control higher-voltage devices safely. The relay automatically switches ON or OFF connected devices according to system conditions and programmed instructions. It improves automation and system control efficiency.

III. RESULTS AND DISCUSSION

The Smart Spraying Rover was successfully designed, developed, and tested for intelligent monitoring and automation applications. The rover demonstrated smooth movement and reliable system operation during testing. The RFID sensor accurately detected authorized tags and ensured secure system activation.

The ESP32-CAM module successfully captured images in real time, and the Edge Impulse platform effectively processed the data for classification purposes. The AI model demonstrated accurate detection and monitoring performance under different testing conditions.

The NodeMCU controller efficiently processed sensor data and controlled the rover movement according to programmed instructions. The integrated relay and motor driver system ensured stable rover movement and system automation.

Experimental results showed that the Smart Spring Rover provides reliable automation, efficient monitoring, and intelligent system control. The developed system proved to be cost-effective, portable, and highly useful for smart agriculture and automation applications. Limitations can be minimized in future work through improved optimization and advanced sensor integration.

Parameter	Observation
Rover Movement	Smooth movement
RFID Detection	Successful
Camera Performance	Real-time monitoring
Battery Supply	Stable operation
AI Detection	Accurate result
Overall Performance	Successful

Table I: Performance Observation



IV. CONCLUSION

The Smart Spring Rover was successfully designed and developed for intelligent monitoring and automation applications. The system effectively integrated ESP32-CAM, NodeMCU ESP8266, RFID sensor, and Edge Impulse technology to achieve real-time monitoring and smart operation. The rover demonstrated smooth movement, reliable RFID detection, and accurate AI-based monitoring during testing. The developed system proved to be cost-effective, portable, and useful for smart agriculture and automation applications. Future improvements can include advanced sensors, improved AI accuracy, and enhanced wireless communication for better performance.

The developed rover successfully demonstrated real-time image capturing, RFID-based authentication, and automated movement under programmed conditions. The ESP32-CAM module effectively captured images for monitoring and detection purposes, while the RFID sensor provided secure and reliable object identification. The integration of Edge Impulse enabled TinyML-based artificial intelligence processing, improving intelligent decision-making and monitoring accuracy within the system.

During experimental testing, the Smart Spring Rover showed smooth movement, stable communication between hardware components, reliable RFID tag detection, and efficient monitoring performance. The NodeMCU controller successfully processed sensor inputs and controlled the rover according to programmed instructions, ensuring proper system automation and efficient operation. The battery-powered design improved portability and enabled the rover to function efficiently in different operational environments. Although minor limitations such as network delay, environmental lighting conditions, and sensor sensitivity were observed during operation, the overall system performance remained successful and reliable. These limitations can be minimized in future work through improved hardware optimization, advanced AI model training, and enhanced communication systems.

ACKNOWLEDGMENT

We express our sincere gratitude to the faculty members and staff of Shatabdi Institute of Engineering and Research, affiliated with Savitribai Phule Pune University, for their valuable guidance, encouragement, and support throughout the development of the **Smart Spraying Rover** project. We would also like to sincerely thank our project guide, Sapna Jadhav, and all contributors for providing technical assistance, valuable resources, and continuous motivation during the successful completion of this project. Finally, we express our heartfelt gratitude to our family and friends for their constant support, encouragement, and cooperation throughout the project development process.

REFERENCES

- [1] S. Monk, *Programming Arduino: Getting Started with Sketches*, 2nd ed. New York, NY, USA: McGraw-Hill, 2016.
- [2] J. Boxall, *Arduino Workshop: A Hands-On Introduction with 65 Projects*. San Francisco, CA, USA: No Starch Press, 2013.
- [3] M. Margolis, *Arduino Cookbook*, 3rd ed. Sebastopol, CA, USA: O'Reilly Media, 2020.
- [4] Espressif Systems, *ESP32-CAM Technical Reference Manual*.
- [5] Espressif Systems, *ESP8266 NodeMCU Documentation*.
- [6] MFRC522 RFID Module Documentation.
- [7] P. Horowitz and W. Hill, *The Art of Electronics*, 3rd ed. Cambridge, U.K.: Cambridge University Press, 2015.
- [8] A. Malvino and D. Bates, *Electronic Principles*, 8th ed. New York, NY, USA: McGraw-Hill, 2015.
- [9] R. Boylestad and L. Nashelsky, *Electronic Devices and Circuit Theory*, 11th ed. New Delhi, India: Pearson, 2013.



- [10] S. Franco, *Design with Operational Amplifiers and Analog Integrated Circuits*, 4th ed. New York, NY, USA: McGraw-Hill, 2014.
- [11] K. Ashton, "That 'Internet of Things' Thing," *RFID Journal*, 2009.
- [12] S. Haykin, *Communication Systems*, 5th ed. New York, NY, USA: Wiley, 2009
- [13] B. Siciliano and O. Khatib, *Springer Handbook of Robotics*. Berlin, Germany: Springer, 2016.

- [14] A. McEwen and H. Cassimally, *Designing the Internet of Things*. Chichester, U.K.: Wiley, 2013..
- [15] H. Karl and A. Willig, *Protocols and Architectures for Wireless Sensor Networks*. Hoboken, NJ, USA: Wiley, 2005.