



Solar Air Purifier and Monitoring

Ganesh Rajaram Kadam
J.C.E.P Killemachindrada

Prathamesh Bajarang Sawant
J.C.E.P Killemachindrada

Abhijeet Ashok Jadhav
J.C.E.P Killemachindrada

Rushikesh Raju Sonavane
J.C.E.P Killemachindrada

Nikhil Sanjay Raval
J.C.E.P Killemachindrada

Dr.A.P.Bhosale
Assistant Professor
J.C.E.P Killemachindrada

How to Cite this Article:

Kadam, G. R., Sawant, P. B., Jadhav, A. A., Sonavane, R. R. & Raval, N. S. (2026). Solar Air Purifier and Monitoring. International Journal of Creative and Open Research in Engineering and Management, <i>02</i>(6).
<https://doi.org/10.55041/ijcope.v2i6.066>

License:

This article is published under the terms of the Creative Commons Attribution 4.0 International License (CC BY 4.0), which permits unrestricted use, distribution, and reproduction in any medium, provided the original author(s) and the source are credited.

© The Author(s). Published by International Journal of Creative and Open Research in Engineering and Management.



<https://doi.org/10.55041/ijcope.v2i6.066>

Abstract:

Air pollution has become a major environmental and health concern due to rapid industrialization and increasing vehicular emissions. Poor air quality can cause respiratory diseases, allergies, and other health problems, making air purification essential for maintaining a healthy indoor environment. This project presents the design and fabrication of a low-cost solar-powered air purifier that provides an economical and sustainable solution for improving indoor air quality. The proposed system consists of a pre-filter, particulate filter, activated carbon filter, solar panel, and supporting components. The pre-filter removes larger dust particles, while the filtration system captures fine dust, smoke, and airborne contaminants. The activated carbon filter further removes odors and harmful gases, delivering cleaner and healthier air. By utilizing solar energy as the primary power source, the system reduces electricity consumption and operating costs. The developed air purifier offers an eco-friendly, energy-efficient, and affordable alternative to conventional air purification systems, making it suitable for residential and small-scale indoor applications.

I INTRODUCTION

Air Pollution

Air pollution is a mixture of solid particles and gases in the air. Car emissions, chemicals from factories, dust, pollen and mild spores may be suspended as particles. Air pollution occurs when harmful or excessive quantities of substances including the gases, particles, and biological molecules are introduced into Earth's atmosphere. Of the most polluted cities in the world, 21 out of 30 were in India in 2019. As per a study based on 2016 data, at least 140 million people in India breathe air

that is 10 times or more over the WHO safe limit and 13 of the world's 20 cities with the highest annual levels of air pollution are in India. The 51% of pollution is caused by the industrial pollution, 27% by vehicles, 17% by crop burning and 5% by diwali fireworks. Air pollution contributes to the premature deaths of 2 million Indians every year. Emissions come from vehicles and industry, whereas in rural areas, much of the pollution stems from biomass burning for cooking and keeping warm. In autumn and winter months, large scale crop residue burning in agriculture fields – a cheaper



alternative to mechanical tilling – is a major source of smoke, smog and particulate pollution.

Fig.1 Air Pollution



Rapid Urbanization

Rapid urbanization is the main cause for all means of pollution and air pollution is also in an alarming condition, the increase in population density in city leads to rapid deforestation and also maximum use of automobiles which produce harmful gases into the atmosphere. The death rates have increased drastically due to these harmful gases causing air pollution which leads to unconditional and unseasonal rain eventually leads to shifting in monsoon and disturbs the ecological cycle.

EFFECTS OF AIR POLLUTION ON HUMAN HEALTH

- Respiratory problems
- Ischemic heart disease
- Stroke
- Chronic obstructive pulmonary disease
- Lung cancer

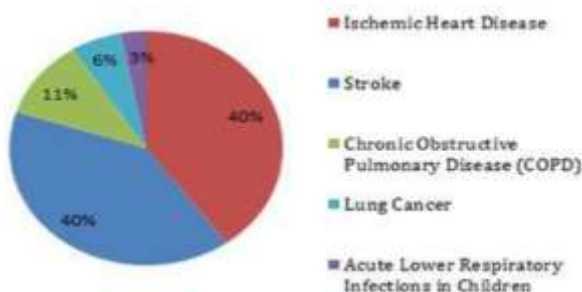

Fig. 2 Effects of air pollution on human health

AIR POLLUTANTS

Particulate matter mainly includes Carbon monoxide. PM2.5 and PM10 refers to the atmospheric particulate

Fig.3 Particulate Matter



matter that have diameter of less than 2.5 micro meters, the particles in this category are so small that they can only be detected with an electron microscope, the particulate matter arises from power plants, motor vehicles, airplanes, residential wood burning, forest fires, agricultural burning, volcanic eruptions and dust storms etc. As shown in the fig above the human hair diameter is 50-70 microns and PM2.5 particles are so small that it varies from 10 microns to 2.5 microns or even less, since they are so small and light, fine particles tend to stay longer in the air than heavier particles, this increases the chances of humans and animals inhaling them into the bodies. Owing to their minute size, particles smaller than 2.5 micro meters are able to bypass the nose and throat and penetrate deep into the lungs and some may even enter the circulatory system, these particulate matter cause asthma, cardiovascular diseases, lung cancer and so on.

II PROBLEM STATEMENT

Air pollution has become a serious problem these modern days. Air pollution is present outside in the environment and has become difficult to provide safety inside the house. This polluted air can cause many serious health problems in cities. Due to this people are suffering from breathing problems like Asthma, Sinus, suffering from any lung problem



III METHODOLOGY

Fig.4 Block Diagram

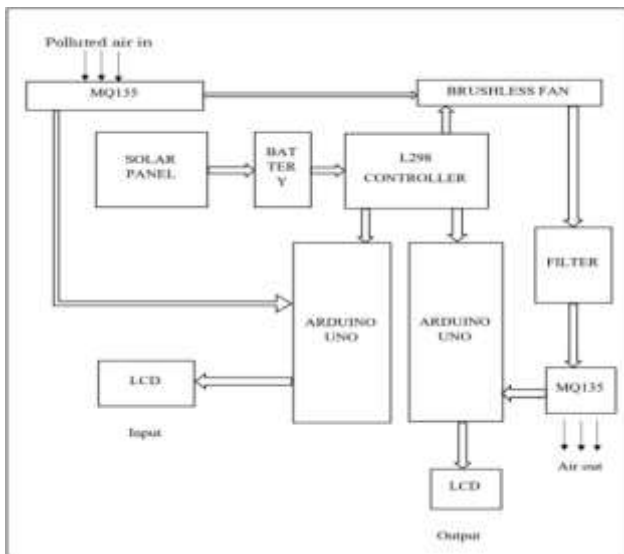

The above figure shows the block diagram of the solar air purifier that we are implemented in our paper.

- The solar panel of the range 10 watt is used which captures the sun light, which is then given to the battery to store the converted solar energy into electrical energy.
- The rating of the battery used is 12v and 1.3 amps. Here another end of battery is connected to L298 controller. It converts 12 V supply into 5v for Arduino uno board.
- From the controller two connections are given to two Arduino boards and another connection is given to brushless fan.
- To the brushless fan one MQ135 sensor is connected also from the fan a connection is given to filter. MQ135 measure the air in the range of 10 meters.
- Brushless fan is used to suck the air and push the air towards the filter.
- From the filter connection is given to another MQ135 sensor. Filter adsorbs the polluted air and makes the bonding.
- Now both the sensors given to two Arduino boards to measure the air quantity, also two LCDs are given to the two Arduino boards to display input and output from the module.

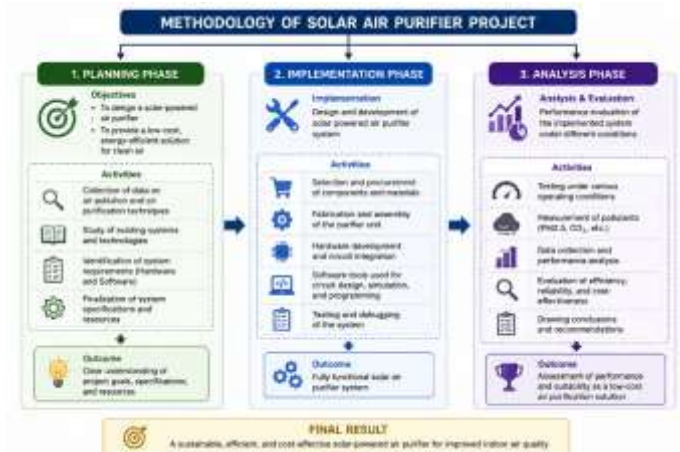

Fig.5 Methodology for Solar-Powered Air Purifier

The paper carried out in three major phases: planning, implementation, and analysis. During the planning phase, relevant data regarding air pollution and air purification techniques were collected and studied. The hardware and software requirements necessary for the development of the solar-powered air purifier were identified and finalized. This stage provided a clear understanding of the project objectives, system specifications, and the resources required for successful execution.

In the implementation phase, the designed system was assembled and tested using the selected components. Hardware activities included material selection, procurement, and fabrication of the purifier unit, while software tools were utilized for circuit design, simulation, report generation, and performance analysis. After implementation, the system was evaluated under various operating conditions to assess its effectiveness. The results obtained were analyzed to determine the purifier's performance, and conclusions were drawn regarding its efficiency, reliability, and suitability as a low-cost solution for improving indoor air quality.

IV DESIGN METHODOLOGY

General Requirements of Machine Design

The design of any engineering product should satisfy functional, economic, and safety requirements. The following factors were considered during the design of the solar-powered air purifier:

- High productivity and efficient operation.
- Ability to achieve the required performance and filtration efficiency.
- Simplicity in design and ease of fabrication.
- Safe and convenient operation for the user.
- Low manufacturing and maintenance cost.
- Attractive appearance and compact structure.
- Reliability and durability under normal operating conditions.



Design Procedure

Before the manufacturing process begins, it is essential to develop a proper design of the product. A well-planned design helps reduce production costs and ensures effective performance of the final product. The design process involves studying the requirements, selecting suitable components, and evaluating the feasibility of the proposed system.

The product design mainly consists of the following stages:

- Functional Design
- Product Design
- Engineering Design

These stages ensure that the developed system meets performance, safety, and economic requirements.

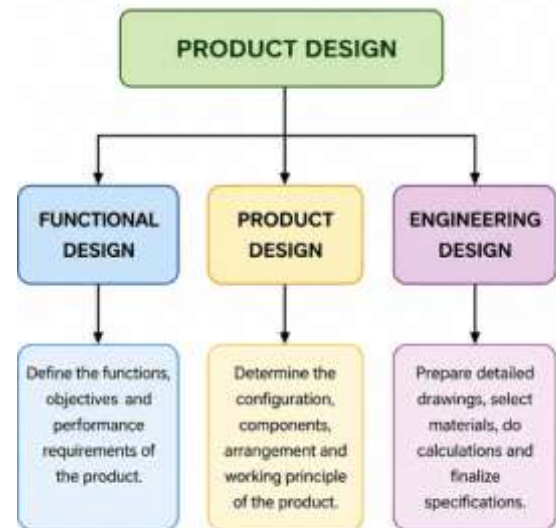

Fig.7 Product Design Hierarchy

Design Procedure for the Product

The following systematic procedure was adopted for the design and development of the solar-powered air purifier:

1. Define the problem statement and clearly identify the objectives of the project.
2. Select a suitable mechanism and operating principle for air purification.
3. Determine the operating conditions, airflow requirements, and power requirements of the system.
4. Select appropriate materials and components based on performance, availability, and cost.
5. Evaluate design parameters and allowable stresses to ensure safe operation.
6. Study existing systems and identify limitations and improvement opportunities.
7. Determine the dimensions and specifications of individual components.
8. Modify the design based on practical considerations, manufacturing feasibility, and previous experience.
9. Prepare detailed assembly drawings and component drawings with complete specifications.
10. Finalize the manufacturing process, material requirements, and quality standards for fabrication

V MANUFACTURING AND STRUCTURAL DESIGN

Manufacturing involves converting raw materials into a finished product using machines, tools, and human resources. After completing the design stage, the solar-powered air purifier was fabricated using workshop equipment such as drilling, cutting, grinding, and welding machines. During the design process, structural analysis was carried out to ensure adequate strength, stability, and safety of the frame. Important machine design considerations such as load conditions, material selection, manufacturability, durability, cost, and ease of operation were taken into account.



Fig.8 Design Procedure Flowchart

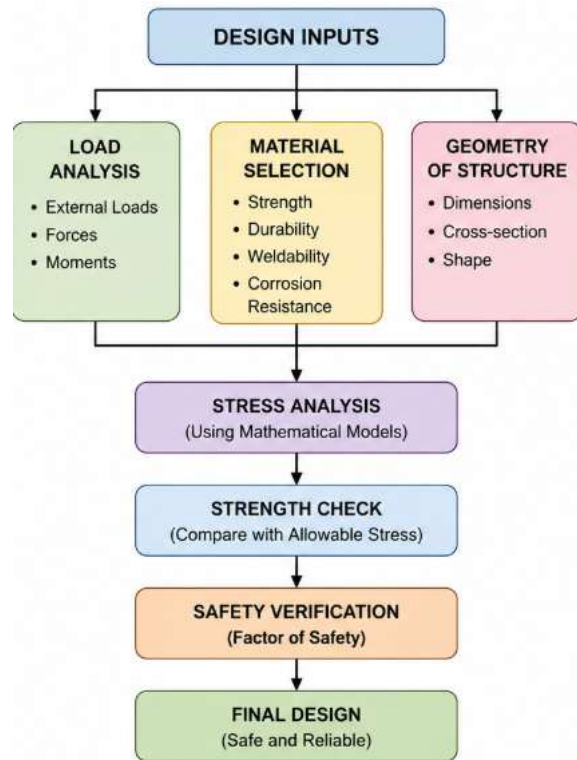

Fig.9 Structural Design and Safety Analysis Flowchart

The square pipe frame was evaluated based on yield strength and moment of inertia calculations, which confirmed that the selected dimensions can safely withstand the expected operating loads without significant deformation. In addition, welded joints were analyzed for shear and tensile stresses, and the results showed that the induced stresses are well below the permissible limits. Therefore, both the frame structure and welded joints are considered safe and reliable for the intended application.

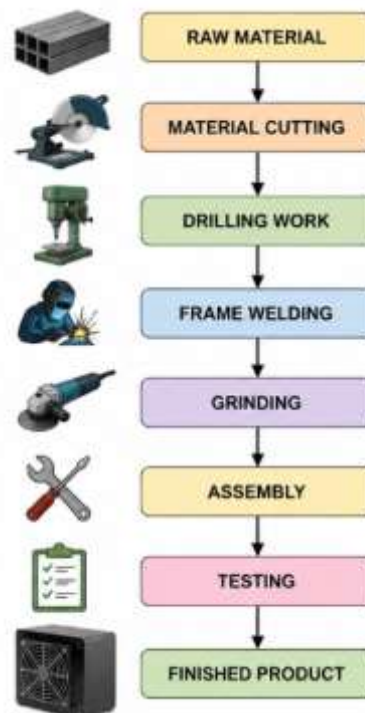

Fig.10 Manufacturing Process Flowchart



VI WORKING PRINCIPLE AND FABRICATION

The proposed solar-powered air purifier operates by utilizing solar energy to power the purification system. A solar panel converts sunlight into electrical energy, which is stored in a rechargeable battery. The stored power is supplied to the control unit, Arduino Uno microcontrollers, MQ135 air quality sensors, LCD displays, and a brushless DC fan. The fan draws polluted air into the purifier and forces it through multiple filtration stages, where dust particles, smoke, harmful gases, and other contaminants are removed. The MQ135 sensors continuously monitor air quality at both the inlet and outlet of the purifier, while the Arduino boards process the sensor data and display the pollution levels on LCD screens in parts per million (ppm). This arrangement allows real-time comparison of air quality before and after filtration, demonstrating the effectiveness of the system. The fabrication process involved collecting raw materials, cutting and welding mild-steel sections to form the frame, assembling the fan, filters, battery, solar panel, sensors, and control circuitry, followed by testing and performance evaluation. The figure illustrates the complete working principle of the solar-powered air purifier, showing the flow of energy from the solar panel to the battery and electronic control system, along with the airflow path from polluted air intake through the filtration unit to the clean air outlet.

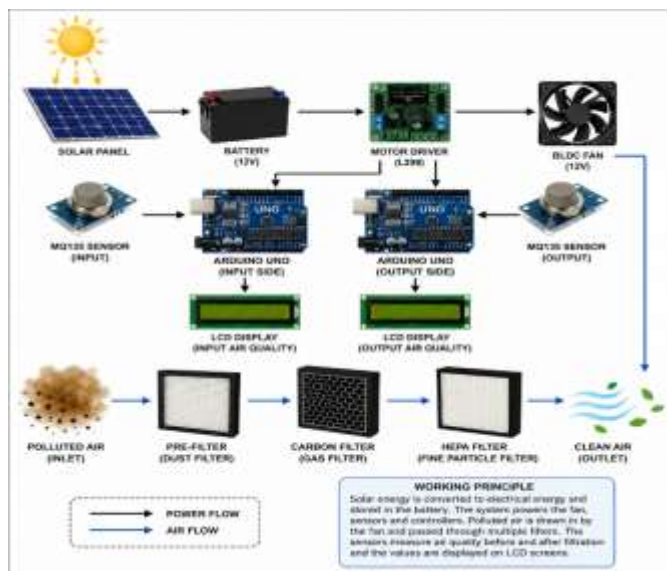

Fig.11 Working Principle of Solar-Powered Air Purifier

VII CONCLUSION

The Solar Air Purifier was successfully designed and developed as a low-cost, eco-friendly, and energy-efficient solution for improving indoor air quality. By utilizing solar energy and an effective filtration system, the purifier demonstrated its ability to reduce airborne pollutants and

provide cleaner air. The project highlights the potential of integrating renewable energy with environmental monitoring technologies to address air pollution challenges. With further enhancements, the system can serve as a sustainable and practical solution for creating healthier living environments.

References

- [1] World Health Organization (WHO), *Air Pollution*, Geneva, Switzerland, 2024.
- [2] United States Environmental Protection Agency (EPA), *Guide to Air Cleaners in the Home*, Washington, DC, USA, 2023.
- [3] J. F. Manwell, J. G. McGowan, and A. L. Rogers, *Wind Energy Explained: Theory, Design and Application*, 2nd ed., Chichester, U.K.: Wiley, 2010.
- [4] M. H. Rashid, *Power Electronics: Circuits, Devices and Applications*, 4th ed., New Delhi, India: Pearson Education, 2014.
- [5] S. Kalogirou, *Solar Energy Engineering: Processes and Systems*, 2nd ed., Academic Press, 2014.
- [6] Arduino, *Arduino Uno Rev3 Technical Specifications*, Arduino Documentation, 2024.
- [7] Hanwei Electronics, *MQ-135 Air Quality Sensor Technical Datasheet*, Zhengzhou, China, 2023.
- [8] A. K. Sawhney, *A Course in Mechanical Measurements and Instrumentation*, 19th ed., New Delhi, India: Dhanpat Rai Publications, 2015.
- [9] V. B. Bhandari, *Design of Machine Elements*, 4th ed., New Delhi, India: McGraw Hill Education, 2017.
- [10] R. K. Jain, *Production Technology*, New Delhi, India: Khanna Publishers, 2016.
- [11] C. R. Kothari and G. Gaurav, *Research Methodology: Methods and Techniques*, 3rd ed., New Delhi, India: New Age International Publishers, 2019.
- [12] A. S. Sedra and K. C. Smith, *Microelectronic Circuits*, 7th ed., New York, NY, USA: Oxford University Press, 2015.